

THE BSF FIBER DIGGING BUCKET HAS BEEN SPECIFICALLY DESIGNED FOR CLEANING AND EXCAVATING NARROW, DEEP TRENCHES. IDEAL FOR LAYING ELECTRICAL CABLES, FIBER OPTICS, AND PIPING, IT ENSURES OPTIMIZED EXCAVATION AIMED AT REDUCING EXECUTION TIMES AND DISPOSAL COSTS. IT ALSO OFFERS EXCELLENT PERFORMANCE IN THE LANDSCAPING SECTOR FOR CREATING CHANNELS, DRAINAGE SYSTEMS, OR IRRIGATION NETWORKS. FURTHERMORE, THE BSF BUCKET IS PERFECT FOR PRECISION DIGGING ON ROADSIDES AND GREEN AREAS, DELIVERING HIGH PERFORMANCE EVEN IN CHALLENGING SOIL CONDITIONS.

STANDARD TECHNICAL FEATURES

- 1 **SPECIFIC PROFILE FOR DEEP EXCAVATIONS WITH A NARROW CROSS-SECTION**
- 2 **WEAR-RESISTANT STEEL COMPONENTS IN THE MOST STRESSED AREAS**
BLADES IN HB500 AND SIDE REINFORCEMENT IN HB450.
- 3 **BUILT-IN SLOTS ON THE BUCKET SIDE PLATE**
TO ENSURE EFFECTIVE WATER DRAINAGE AND FACILITATE THE DISCHARGE OF MATERIAL.
- 4 **IDEAL FOR REMOVING EXCAVATOR WHEEL DEBRIS**

MOD.	BSF65	BSF70	BSF75	BSF75	BSF80
TONS (LB)	1,2 - 1,8 (2645 - 3968)	1,8 - 2,5 (39680 - 5512)	2,5 - 4,0 (5512 - 8818)	4,0 - 6,0 (8818 - 13227)	6,0 - 12,0 (13227 - 26455)

BSF65 MACHINE WEIGHT 1,2 - 1,8 t (2645 - 3968 lb)

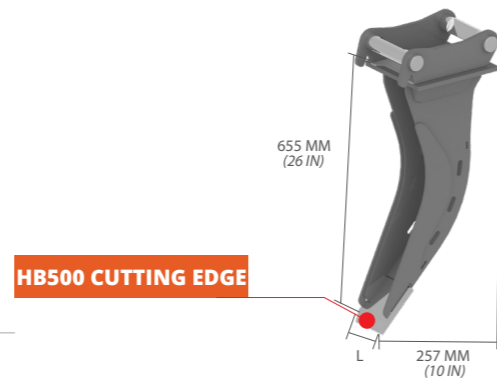
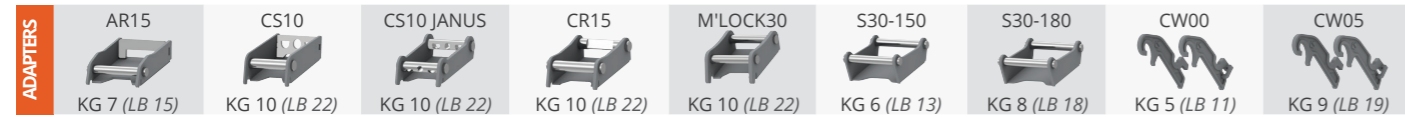

HB500 CUTTING EDGE

L MM (IN)	WEIGHT KG* (LB*)	CAP. SAE L (GAL)	ADAPTERS
80 (3)	18 (39)	6 (1,3)	AF - AR - CS CR - S - M'LOCK CW - CS JANUS
100 (4)	20 (44)	9 (2)	AF - AR - CS CR - S - M'LOCK CW - CS JANUS
120 (5)	22 (48)	11 (2,4)	AF - AR - CS CR - S - M'LOCK CW - CS JANUS

BSF75 MACHINE WEIGHT 2,5 - 4,0 t (5512 - 8818 lb)

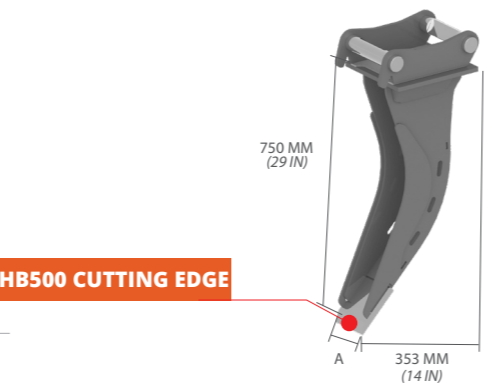

HB500 CUTTING EDGE

L MM (IN)	WEIGHT KG* (LB*)	CAP. SAE L (GAL)	ADAPTERS
80 (3)	36 (79)	8 (1,7)	AF - AR - CS CR - S - M'LOCK CW - CS JANUS
100 (4)	38 (84)	11 (2,4)	AF - AR - CS CR - S - M'LOCK CW - CS JANUS
120 (5)	40 (88)	13 (2,8)	AF - AR - CS CR - S - M'LOCK CW - CS JANUS

*Weight of the tank excluding attachment

BSF70 MACHINE WEIGHT 1,8 - 2,5 t (3968 - 5512 lb)

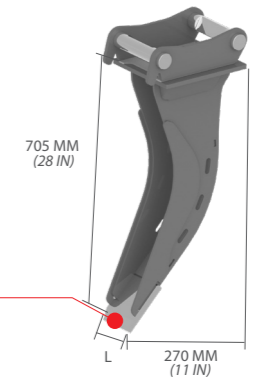
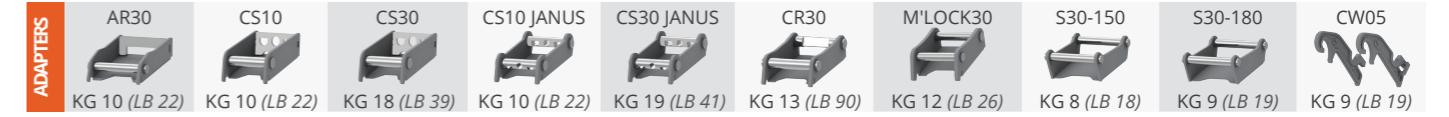

HB500 CUTTING EDGE

L MM (IN)	WEIGHT KG* (LB*)	CAP. SAE L (GAL)	ADAPTERS
80 (3)	26 (57)	7 (1,5)	AF - AR - CS CR - S - M'LOCK CW - CS JANUS
100 (4)	28 (62)	10 (2,2)	AF - AR - CS CR - S - M'LOCK CW - CS JANUS
120 (5)	30 (66)	12 (2,6)	AF - AR - CS CR - S - M'LOCK CW - CS JANUS

BSF75 MACHINE WEIGHT 4,0 - 6,0 t (8818 - 13227 lb)

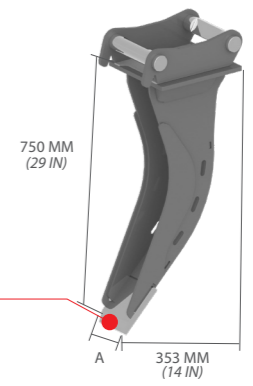

HB500 CUTTING EDGE

L MM (IN)	WEIGHT KG* (LB*)	CAP. SAE L (GAL)	ADAPTERS
80 (3)	36 (79)	8 (1,7)	AF - AR - CS CR - S - M'LOCK CW - CS JANUS
100 (4)	38 (84)	11 (2,4)	AF - AR - CS CR - S - M'LOCK CW - CS JANUS
120 (5)	40 (88)	13 (2,8)	AF - AR - CS CR - S - M'LOCK CW - CS JANUS

*Weight of the tank excluding attachment

BSF80 MACHINE WEIGHT 6,0 - 12,0 t (13227 - 26455 lb)

ADAPTERS	AR70	CS80	CS80 JANUS	CR70	M'LOCK100	M'LOCK180	S45	S50	CW10
	KG 24 (LB 53)	KG 44 (LB 97)	KG 46 (LB 101)	KG 34 (LB 75)	KG 35 (LB 77)	KG 68 (LB 150)	KG 28 (LB 62)	KG 29 (LB 64)	KG 23 (LB 51)

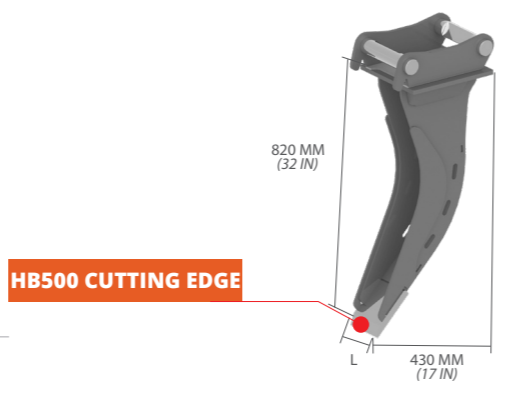

L MM (IN)	WEIGHT KG* (LB*)	CAP. SAE L (GAL)	ADAPTERS
80 (3)	55 (121)	10 (2,2)	AF - AR - CS CR - S - M'LOCK CW - CS JANUS
100 (4)	57 (126)	13 (2,8)	AF - AR - CS CR - S - M'LOCK CW - CS JANUS
120 (5)	59 (130)	16 (3,5)	AF - AR - CS CR - S - M'LOCK CW - CS JANUS



*Weight of the tank excluding attachment