

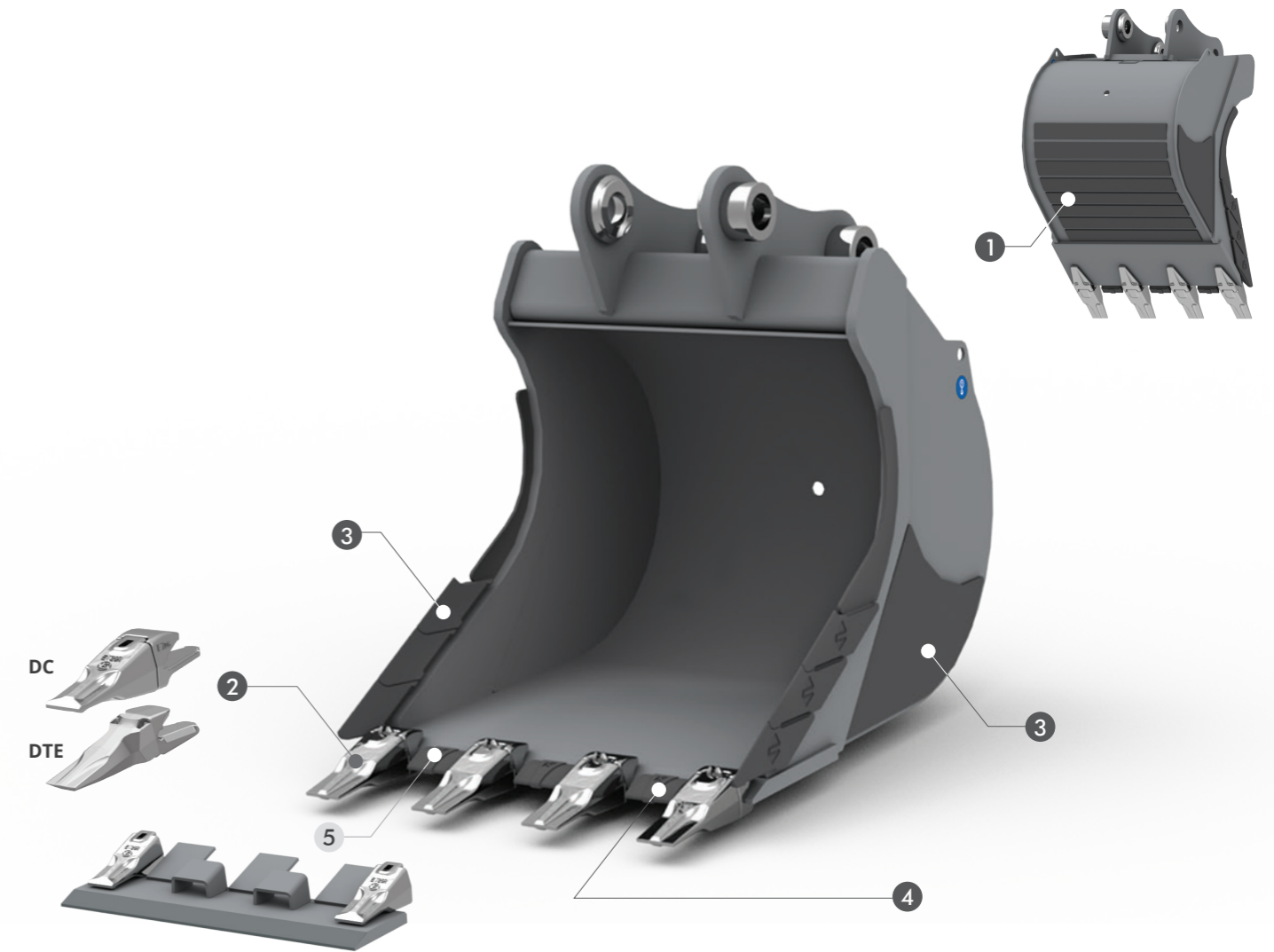

SPEZIALFORM FÜR EINFACHERE UND SICHERE STEINLEGE-EINSÄTZE. EXTREM ROBUSTE AUSFÜHRUNG DER VERSCHLEISSBEANSPRUCHTEN TEILE IN HB400-STAHL.



### STANDARD TECHNISCHE DATEN

- 1 VERSTÄRKTER VERSCHLEISS-SCHUTZ HB400**  
DIE WAAGERECHTEN VERSTÄRKUNGEN BIETEN OPTIMALEN VERSCHLEISSSCHUTZ UND SCHÜTZEN DIE STRUKTUR.
- 2 ZÄHNE DC ZÄHNE DTE**
- 3 MESSER-SEITENSCHNEIDEN HB400 SEITENVERSTÄRKUNGEN**  
DIE SEITENSCHNEIDEN SIND AUS HB 400. SIE SCHNEIDEN DAS MATERIAL BEIM ERDAUSHUB UND DIENEN ZUSÄTZLICH ALS VERSCHLEISSSCHUTZ.
- 4 VERSTÄRKTES MESSER**  
VERSCHLEISSSTEILE AUS HB400 BIS ZU 10 TONNEN.  
SCHNEIDE AUS HB400 FÜR LÖFFEL ÜBER 10 TONNEN.

### ZUBEHÖR

- 5 AUFSTECKMESSER**  
DAS AUFSTECKMESSER EIGNET SICH FÜR DIE FERTIGSTELLUNG / EINEBNUNG, DA ES KEINE SPUREN DER ZÄHNE HINTERLÄSST. WEITERHIN ERHÖHT ES DAS LADEVOLUMEN. IM FALLE EINER ERSATZBESTELLUNG WIRD DAS AUFSTECKMESSER UNMONTIERT GELIEFERT.

MOD.	MIDI							EXCAVATOR			
	SB38	SB45	SB53	SB62	SB67	SB73	SB80	SB85	SB92 HD	SB100 HD	SB110 HD
TONS	1,2 - 1,8	1,8 - 2,5	2,5 - 4,0	4,0 - 5,0	5,0 - 7,5	7,5 - 10,0	10,0 - 12,0	12,0 - 14,0	12,0 - 14,0	14,0 - 18,0	18,0 - 22,0

## SB38 MASCHINENGEWICHT 1,2 - 1,8

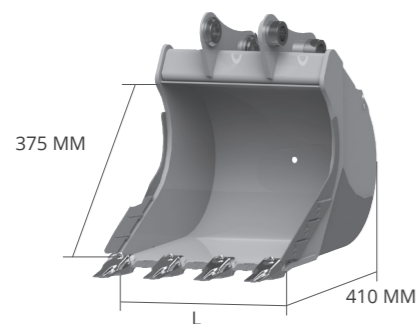
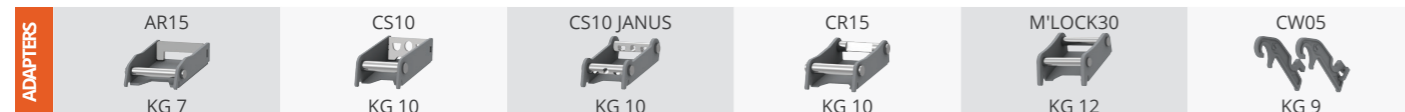

L MM	GEWICHT KG*	KAP. SAE L	ZÄHNE N°	ADAPTERS
200	17	15	2	AF - AR - CS
				CR - CM
				CW - CS JANUS
250	19	20	DF2 DC3 DE3	AF - AR - CS
				CR - CM
				CW - CS JANUS
300	22	25	3	AF - AR - CS
				CR - CM
				CW - CS JANUS
350	24	31	3	AF - AR - CS
				CR - CM
				CW - CS JANUS
400	28	37	3	AF - AR - CS
				CR - CM
				CW - CS JANUS
450	31	43	3	AF - AR - CS
				CR - CM
				CW - CS JANUS
500	35	49	4	AF - AR - CS
				CR - CM
				CW - CS JANUS
600	39	61	4	AF - AR - CS
				CR - CM
				CW - CS JANUS
700	44	74	5	AF - AR - CS
				CR - CM
				CW - CS JANUS

\* Gewicht des Löffel ohne Anbauteile und Zähne

## SB45 MASCHINENGEWICHT 1,8 - 2,5

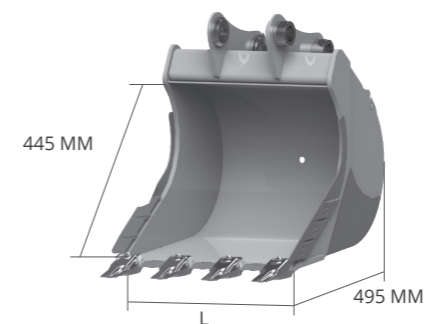
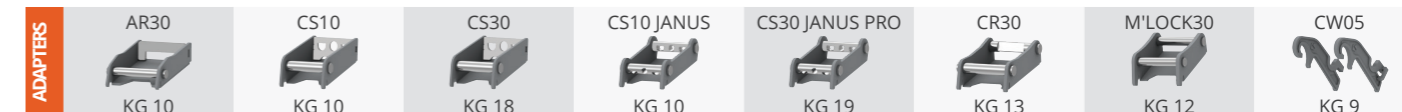

L MM	GEWICHT KG*	KAP. SAE L	ZÄHNE N°	ADAPTERS
250	26	25	DF2 DC3 DE3	AF - AR - CS
				CR - CM
				CW - CS JANUS
300	29	33	3	AF - AR - CS
				CR - CM
				CW - CS JANUS
350	32	40	3	AF - AR - CS
				CR - CM
				CW - CS JANUS
400	36	48	3	AF - AR - CS
				CR - CM
				CW - CS JANUS
450	39	56	3	AF - AR - CS
				CR - CM
				CW - CS JANUS
500	43	65	4	AF - AR - CS
				CR - CM
				CW - CS JANUS
600	50	82	4	AF - AR - CS
				CR - CM
				CW - CS JANUS
700	56	100	5	AF - AR - CS
				CR - CM
				CW - CS JANUS
800	65	117	5	AF - AR - CS
				CR - CM
				CW - CS JANUS

\* Gewicht des Löffel ohne Anbauteile und Zähne

### ZUBEHÖR

AUFSTECKMESSER	5
----------------	---

### ZUBEHÖR

AUFSTECKMESSER	5
----------------	---

## SB53 MASCHINENGEWICHT 2,5 - 4,0

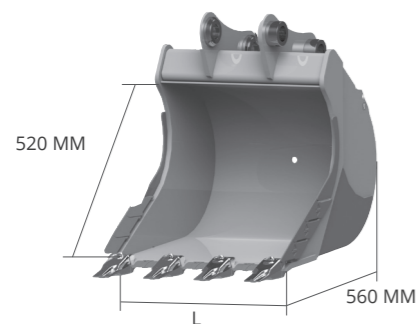
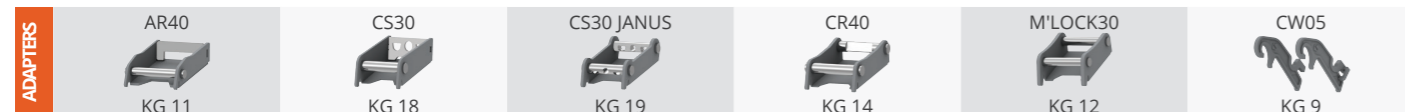

L MM	GEWICHT KG*	KAP. SAE L	ZÄHNE N°	ADAPTERS
250	37	32	2	AF - AR - CS
				CR - CM
				CW - CS JANUS
300	40	41	3	AF - AR - CS
				CR - CM
				CW - CS JANUS
350	46	51	3	AF - AR - CS
				CR - CM
				CW - CS JANUS
400	51	61	3	AF - AR - CS
				CR - CM
				CW - CS JANUS
450	55	72	3	AF - AR - CS
				CR - CM
				CW - CS JANUS
500	59	82	4	AF - AR - CS
				CR - CM
				CW - CS JANUS
600	67	105	4	AF - AR - CS
				CR - CM
				CW - CS JANUS
700	76	127	5	AF - AR - CS
				CR - CM
				CW - CS JANUS
800	85	152	5	AF - AR - CS
				CR - CM
				CW - CS JANUS
900	93	175	5	AF - AR - CS
				CR - CM
				CW - CS JANUS

\* Gewicht des Löffel ohne Anbauteile und Zähne

## SB62 MASCHINENGEWICHT 4,0 - 5,0

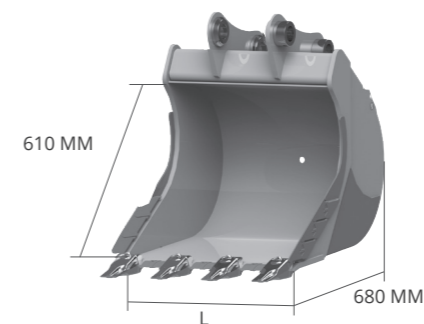
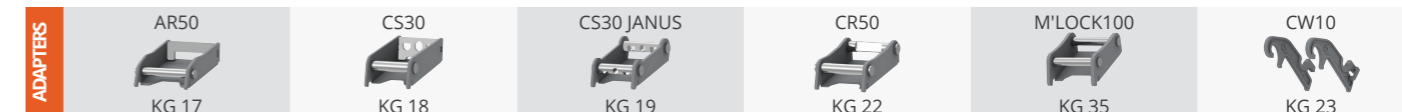

L MM	GEWICHT KG*	KAP. SAE L	ZÄHNE N°	ADAPTERS
250	57	45	2	AF - AR - CS
				CR - CM
				CW - CS JANUS
300	63	58	3	AF - AR - CS
				CR - CM
				CW - CS JANUS
350	68	71	3	AF - AR - CS
				CR - CM
				CW - CS JANUS
400	74	85	3	AF - AR - CS
				CR - CM
				CW - CS JANUS
450	79	100	3	AF - AR - CS
				CR - CM
				CW - CS JANUS
500	86	115	4	AF - AR - CS
				CR - CM
				CW - CS JANUS
600	97	147	4	AF - AR - CS
				CR - CM
				CW - CS JANUS
700	109	180	5	AF - AR - CS
				CR - CM
				CW - CS JANUS
800	121	213	5	AF - AR - CS
				CR - CM
				CW - CS JANUS
900	133	248	6	AF - AR - CS
				CR - CM
				CW - CS JANUS
1000	145	282	6	AF - AR - CS
				CR - CM
				CW - CS JANUS

\* Gewicht des Löffel ohne Anbauteile und Zähne

### ZUBEHÖR

AUFSTECKMESSER	5
----------------	---

### ZUBEHÖR

AUFSTECKMESSER	5
----------------	---

## SB67 MASCHINENGEWICHT 5,0 - 7,5

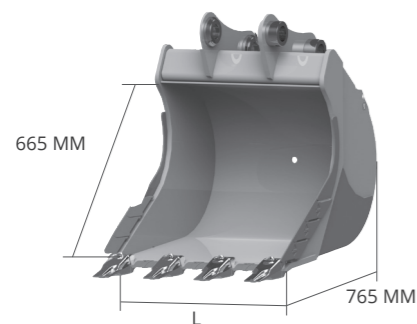
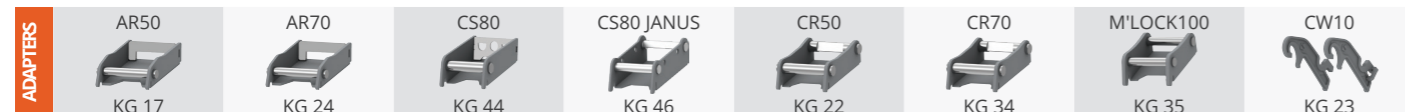

L MM	GEWICHT KG*	KAP. SAE L	ZÄHNE N°	ADAPTERS
300	83	68	3	AF - AR - CS
				CR - CM
				CW - CS JANUS
350	92	84	3	AF - AR - CS
				CR - CM
				CW - CS JANUS
400	101	101	3	AF - AR - CS
				CR - CM
				CW - CS JANUS
450	109	118	3	AF - AR - CS
				CR - CM
				CW - CS JANUS
500	117	137	4	AF - AR - CS
				CR - CM
				CW - CS JANUS
600	134	174	4	AF - AR - CS
				CR - CM
				CW - CS JANUS
700	150	214	5	AF - AR - CS
				CR - CM
				CW - CS JANUS
800	167	254	5	AF - AR - CS
				CR - CM
				CW - CS JANUS
900	183	295	6	AF - AR - CS
				CR - CM
				CW - CS JANUS
1000	199	338	6	AF - AR - CS
				CR - CM
				CW - CS JANUS

\* Gewicht des Löffel ohne Anbauteile und Zähne

## SB73 MASCHINENGEWICHT 7,5 - 10,0

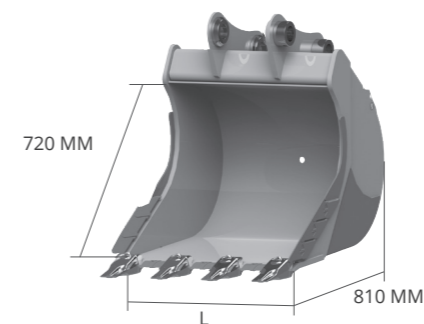

L MM	GEWICHT KG*	KAP. SAE L	ZÄHNE N°	ADAPTERS
300	95	76	2	AF - CS
				CR - CM
				CW - CS JANUS
350	103	94	3	AF - CS
				CR - CM
				CW - CS JANUS
400	110	113	3	AF - CS
				CR - CM
				CW - CS JANUS
450	120	133	3	AF - CS
				CR - CM
				CW - CS JANUS
500	130	153	3	AF - CS
				CR - CM
				CW - CS JANUS
600	148	196	4	AF - CS
				CR - CM
				CW - CS JANUS
700	166	240	4	AF - CS
				CR - CM
				CW - CS JANUS
800	184	286	5	AF - CS
				CR - CM
				CW - CS JANUS
900	202	333	5	AF - CS
				CR - CM
				CW - CS JANUS
1000	220	379	5	AF - CS
				CR - CM
				CW - CS JANUS
1100	238	430	5	AF - CS
				CR - CM
				CW - CS JANUS

\* Gewicht des Löffel ohne Anbauteile und Zähne

### ZUBEHÖR

AUFSTECKMESSER	5
----------------	---

### ZUBEHÖR

AUFSTECKMESSER	5
----------------	---

## SB80 MASCHINENGEWICHT 10,0 - 12,0

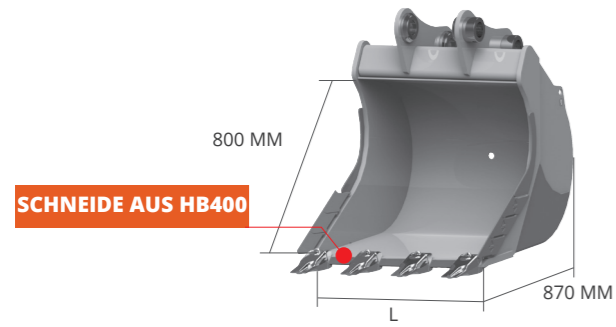
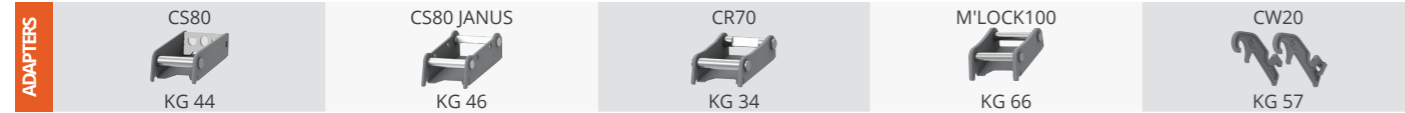

### ZUBEHÖR

AUFSTECKMESSER 5

L MM	GEWICHT KG*	KAP. SAE L	ZÄHNE N°	ADAPTERS
300	119	86	2	AF - CS
				CR - CM - CS JANUS
				CW
350	128	107	3	AF - CS
				CR - CM - CS JANUS
				CW
400	141	129	3	AF - CS
				CR - CM - CS JANUS
				CW
450	151	151	3	AF - CS
				CR - CM - CS JANUS
				CW
500	162	174	3	AF - CS
				CR - CM - CS JANUS
				CW
600	182	222	4	AF - CS
				CR - CM - CS JANUS
				CW
700	203	273	4	AF - CS
				CR - CM - CS JANUS
				CW
800	222	325	5	AF - CS
				CR - CM - CS JANUS
				CW
900	242	379	5	AF - CS
				CR - CM - CS JANUS
				CW
1000	261	433	5	AF - CS
				CR - CM - CS JANUS
				CW
1100	282	486	5	AF - CS
				CR - CM - CS JANUS
				CW
1200	303	546	6	AF - CS
				CR - CM - CS JANUS
				CW
1300	323	602	6	AF - CS
				CR - CM - CS JANUS
				CW

\* Gewicht des Löffel ohne Anbauteile und Zähne

## SB85 MIDI MASCHINENGEWICHT 12,0 - 14,0

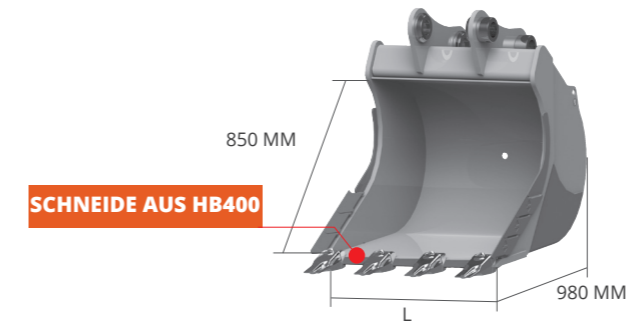
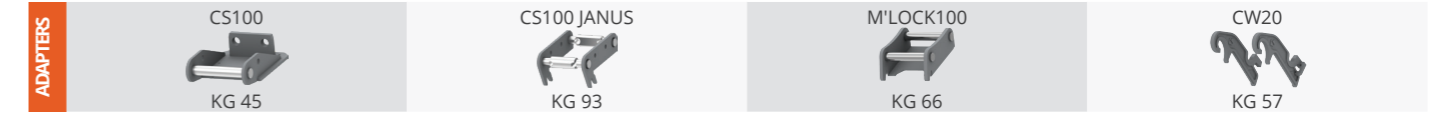

### ZUBEHÖR

AUFSTECKMESSER 5

L MM	GEWICHT KG*	KAP. SAE L	ZÄHNE N°	ADAPTERS
400	197	171	3	AF - CM
				CS - CW
				CS JANUS
500	220	235	3	AF - CM
				CS - CW
				CS JANUS
600	243	300	4	AF - CM
				CS - CW
				CS JANUS
700	266	368	4	AF - CM
				CS - CW
				CS JANUS
800	289	438	5	AF - CM
				CS - CW
				CS JANUS
900	312	510	5	AF - CM
				CS - CW
				CS JANUS
1000	336	584	5	AF - CM
				CS - CW
				CS JANUS
1100	360	657	5	AF - CM
				CS - CW
				CS JANUS
1200	384	730	6	AF - CM
				CS - CW
				CS JANUS
1300	408	810	6	AF - CM
				CS - CW
				CS JANUS

\* Gewicht des Löffel ohne Anbauteile und Zähne

## SB92 HD EXCAVATOR MASCHINENGEWICHT 12,0 - 14,0

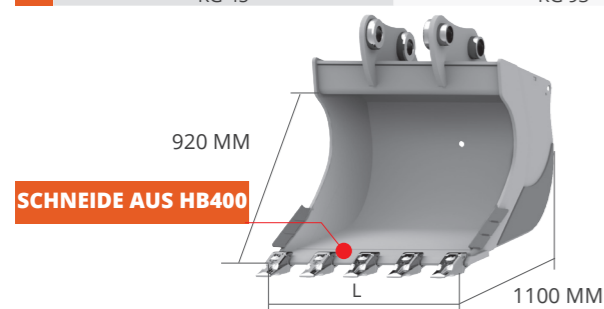
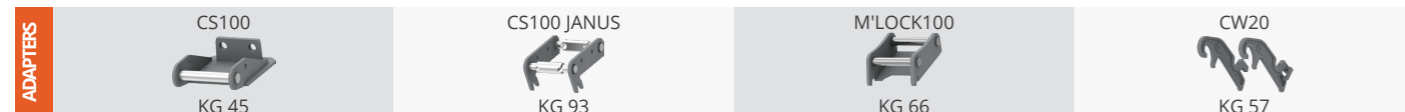

### ZUBEHÖR

L MM	GEWICHT KG*	KAP. SAE L	ZÄHNE N°	ADAPTERS
600	259	337	4	AF - CM
				CS - CW
				CS JANUS
700	280	405	4	AF - CM
				CS - CW
				CS JANUS
800	315	475	4	AF - CM
				CS - CW
				CS JANUS
900	350	547	5	AF - CM
				CS - CW
				CS JANUS
1000	385	622	5	AF - CM
				CS - CW
				CS JANUS
1200	421	783	6	AF - CM
				CS - CW
				CS JANUS

\* Gewicht des Löffel ohne Anbauteile und Zähne

## SB100 HD MASCHINENGEWICHT 14,0 - 18,0

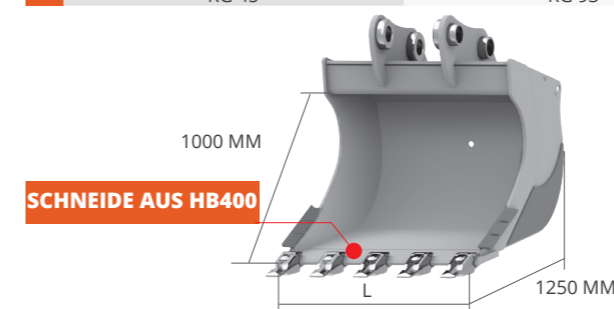
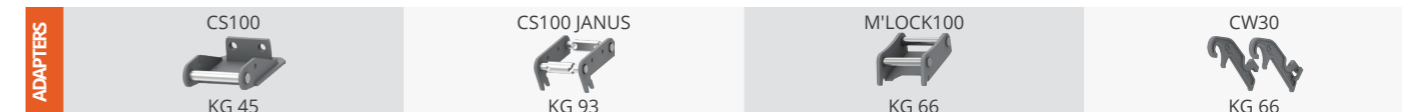

### ZUBEHÖR

L MM	GEWICHT KG*	KAP. SAE L	ZÄHNE N°	ADAPTERS
600	346	398	3	AF - CM
				CS - CW
				CS JANUS
700	386	478	4	AF - CM
				CS - CW
				CS JANUS
800	426	560	4	AF - CM
				CS - CW
				CS JANUS
900	466	644	4	AF - CM
				CS - CW
				CS JANUS
1000	506	730	5	AF - CM
				CS - CW
				CS JANUS
1200	586	909	5	AF - CM
				CS - CW
				CS JANUS

## SB110 HD MASCHINENGEWICHT 18,0 - 22,0

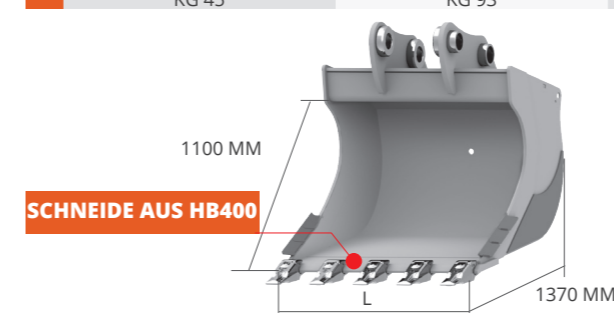

### ZUBEHÖR

L MM	GEWICHT KG*	KAP. SAE L	ZÄHNE N°	ADAPTERS
600	437	464	3	AF - CM
				CS - CW
				CS JANUS
800	539	654	4	AF - CM
				CS - CW
				CS JANUS
1000	641	854	5	AF - CM
				CS - CW
				CS JANUS
1200	743	1064	5	AF - CM
				CS - CW
				CS JANUS
1300	794	1173	6	AF - CM
				CS - CW
				CS JANUS
1400	845	1288	6	AF - CM
				CS - CW
				CS JANUS

\* Gewicht des Löffel ohne Anbauteile und Zähne