



HB400



SU FORMA ALARGADA HACE QUE LA TIERRA NO SE ADHIERA A LOS COSTADOS, FACILITANDO LA DESCARGA DE MATERIALES ARCILLOSOS. SU FONDO DE REJILLA ES ESPECIAL PARA EXCAVACIONES EN TERRENOS MUY HÚMEDOS Y PERMITE SELECCIONAR, SEPARAR Y RECICLAR ÁRIDOS. EL CAZO NETHERLANDS TIENE UNA HOJA DE HB400.



CARACTERÍSTICAS TÉCNICAS ESTÁNDAR

- 1 **PERFIL ALARGADO**
- 2 **CUCHILLA DE HB400**

ACCESORIOS OPCIONALES

- 3 **DIENTES DC O DIENTES DTE**
- 4 **VERSIÓN REVERSIBLE CW**
ESTE ADAPTADOR HACE QUE EL CAZO SEA REVERSIBLE.

MOD.	VN35	VN41	VN52	VN60	VN66	VN75	VN85
TONS	0,6 - 1,2	1,2 - 1,8	1,8 - 2,5	2,5 - 4,0	4,0 - 6,0	6,0 - 7,5	7,5 - 12,0

VN35 PESO MÁQUINA 0,6 - 1,2

ADAPTERS

CW5



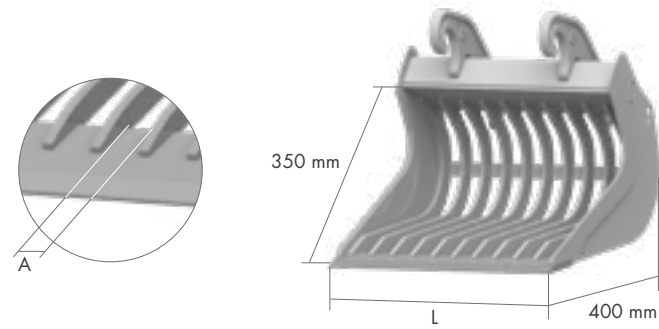

KG 9



ACCESORIOS OPCIONALES

4	4	5
Dientes DC	Dientes DTE	Versión reversible CW

L mm	A mm	PESO Kg*	CAP. SAE l		
400	53	24	32	AF	
400	53	24	32	CW	
500	50	29	42	AF	
500	50	29	42	CW	
600	49	33	52	AF	
600	49	33	52	CW	

VN41 PESO MÁQUINA 1,2 - 1,8

ADAPTERS

CW5



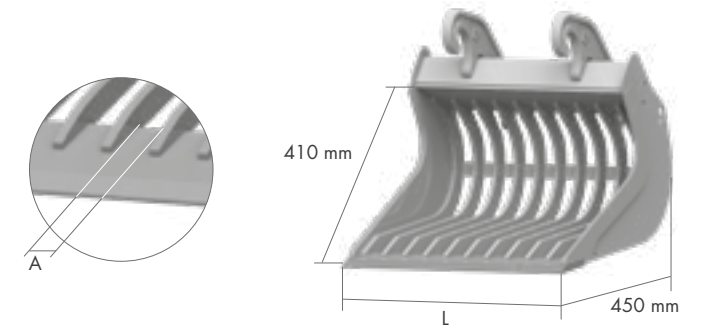

KG 9



ACCESORIOS OPCIONALES

4	4	5
Dientes DC	Dientes DTE	Versión reversible CW

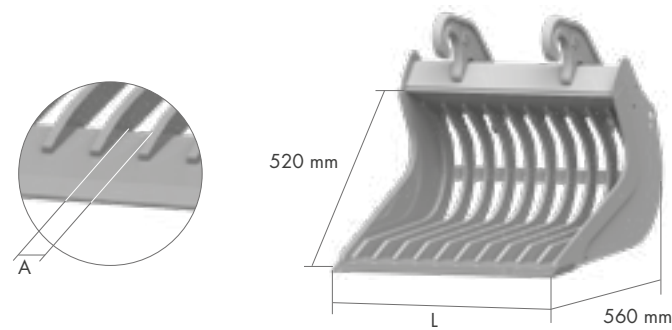

L mm	A mm	PESO Kg*	CAP. SAE l		
400	53	29	42	AF	
400	53	29	42	CW	
500	50	34	55	AF	
500	50	34	55	CW	
600	49	39	67	AF	
600	49	39	67	CW	
700	52	44	80	AF	
700	52	44	80	CW	

VN52 PESO MÁQUINA 1,8 - 2,5



ACCESORIOS OPCIONALES

4	4	5
Dientes DC	Dientes DTE	Versión reversible CW

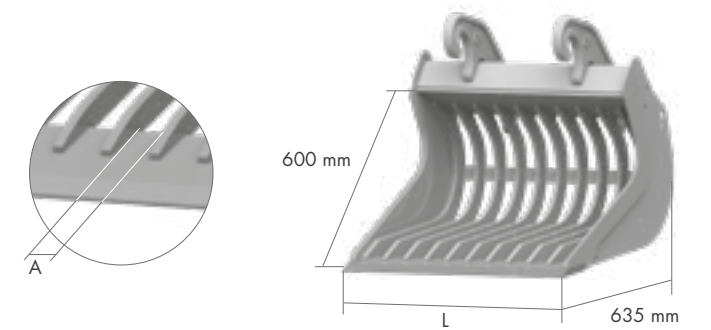

L mm	A mm	PESO Kg*	CAP. SAE l		
500	56	44	77	AF	
500	56	44	77	CW	
600	52	50	96	AF	
600	52	50	96	CW	
700	56	58	115	AF	
700	56	58	115	CW	
800	53	64	135	AF	
800	53	64	135	CW	

VN60 PESO MÁQUINA 2,5 - 4,0



ACCESORIOS OPCIONALES

4	4	5
Dientes DC	Dientes DTE	Versión reversible CW

L mm	A mm	PESO Kg*	CAP. SAE l		
500	56	61	106	AF	
500	56	61	106	CW	
600	52	70	132	AF	
600	52	70	132	CW	
700	50	81	159	AF	
700	50	81	159	CW	
800	53	89	186	AF	
800	53	89	186	CW	
900	56	98	212	AF	
900	56	98	212	CW	
1000	59	109	239	AF	
1000	59	109	239	CW	

* peso cazo sin enganches

* peso cazo sin enganches

VN66 PESO MÁQUINA 4,0 - 6,0

ADAPTERS

CW10
KG 23

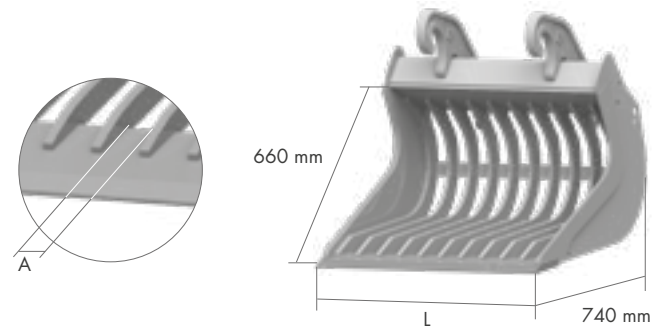

L mm	A mm	PESO Kg*	CAP. SAE l	
600	49	87	153	AF
600	49	87	153	CW
700	53	97	185	AF
700	53	97	185	CW
800	56	107	217	AF
800	56	107	217	CW
900	59	116	250	AFS
900	59	116	250	CW
1000	61	129	282	AF
1000	61	129	282	CW

ACCESORIOS OPCIONALES

4	4	5
Dientes DC	Dientes DTE	Versión reversible CW

VN75 PESO MÁQUINA 6,0 - 7,5

ADAPTERS

CW10
KG 23

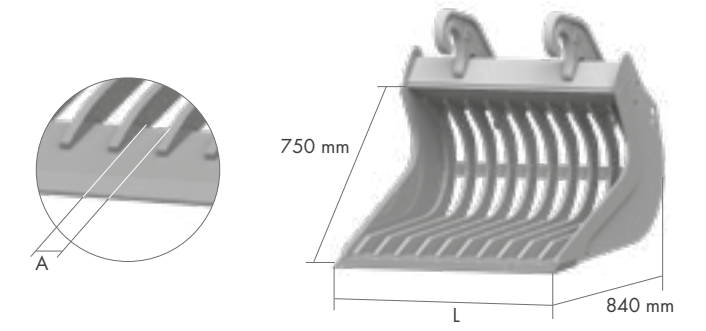

L mm	A mm	PESO Kg*	CAP. SAE l	
600	55	110	183	AF
600	55	110	183	CW
700	59	123	222	AF
700	59	123	222	CW
800	55	140	262	AF
800	55	140	262	CW
900	52	153	302	AF
900	52	153	302	CW
1000	55	166	343	AF
1000	55	166	343	CW
1100	57	183	383	AF
1100	57	183	383	CW

ACCESORIOS OPCIONALES

4	4	5
Dientes DC	Dientes DTE	Versión reversible CW

VN85 PESO MÁQUINA 7,5 - 12,0

ADAPTERS

CW10
KG 23

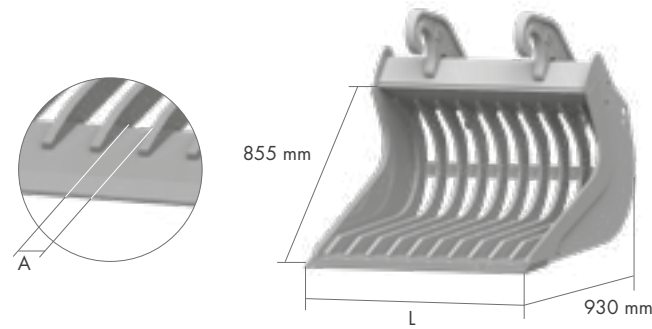

L mm	A mm	PESO Kg*	CAP. SAE l	
800	55	159	331	AF
800	55	159	331	CW
900	53	172	384	AF
900	53	172	384	CW
1000	55	186	437	AF
1000	55	186	437	CW
1100	57	204	490	AF
1100	57	204	490	CW
1200	55	217	542	AF
1200	55	217	542	CW
1300	57	231	595	AF
1300	57	231	595	CW

ACCESORIOS OPCIONALES

4	4	5
Dientes DC	Dientes DTE	Versión reversible CW

* peso cazo sin enganches

* peso cazo sin enganches