



EL CAZO DE REJILLA ESTÁ DISEÑADO PARA LA SELECCIÓN DE PIEDRAS Y ÁRIDOS EN EL TERRENO. LA DISTANCIA ENTRE LAS REJILLAS DETERMINA LA MEDIDA DEL MATERIAL CRIBADO.

CARACTERÍSTICAS TÉCNICAS ESTÁNDAR

1 DIENTES DC DIENTES DTE

ACCESORIOS OPCIONALES

2 HOJA INFERIOR SOLDADA DE HB500 (NO DIENTES)
RECOMENDADA PARA TRABAJAR CON SUELOS SUMAMENTE ABRASIVOS.

	MIDI							EXCAVATOR			
MOD.	VE38	VE45	VE53	VE62	VE67	VE73	VE80	VE85	VE92 GD	VE100 GD	VE110 GD
TONS	0,6 - 1,8	1,8 - 2,5	2,5 - 4,0	4,0 - 5,0	5,0 - 7,5	7,5 - 10,0	10,0 - 12,0	12,0 - 14,0	12,0 - 14,0	14,0 - 18,0	18,0 - 22,0

VE38 PESO MÁQUINA 0,6 - 1,8

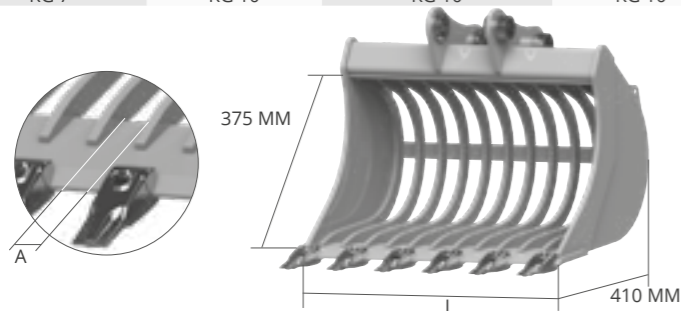

ACCESORIOS OPCIONALES

2
HOJA INFERIOR SOLDADA DE HB500

L MM	A MM	PESO KG*	CAP. SAE L	DIENTES N°	ADAPTERS
500	54	31	49	4	AF - AR - CS
					CR - CM
					CW - CS JANUS PRO
600	51	35	61	4	AF - AR - CS
					CR - CM
					CW - CS JANUS PRO
700	55	42	74	5	AF - AR - CS
					CR - CM
					CW - CS JANUS PRO

VE45 PESO MÁQUINA 1,8 - 2,5

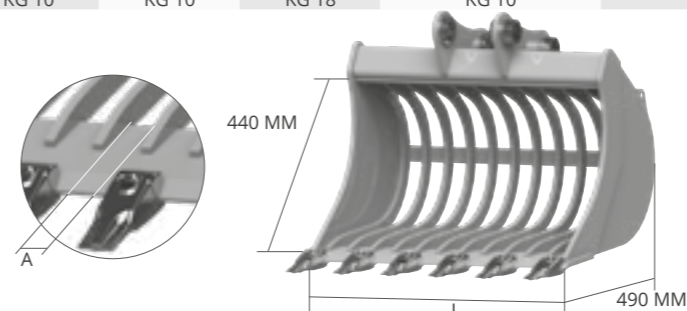

ACCESORIOS OPCIONALES

2
HOJA INFERIOR SOLDADA DE HB500

L MM	A MM	PESO KG*	CAP. SAE L	DIENTES N°	ADAPTERS
600	55	51	79	4	AF - AR - CS
					CR - CM
					CW - CS JANUS PRO
700	59	57	95	5	AF - AR - CS
					CR - CM
					CW - CS JANUS PRO
800	55	64	111	5	AF - AR - CS
					CR - CM
					CW - CS JANUS PRO

VE53 PESO MÁQUINA 2,5 - 4,0

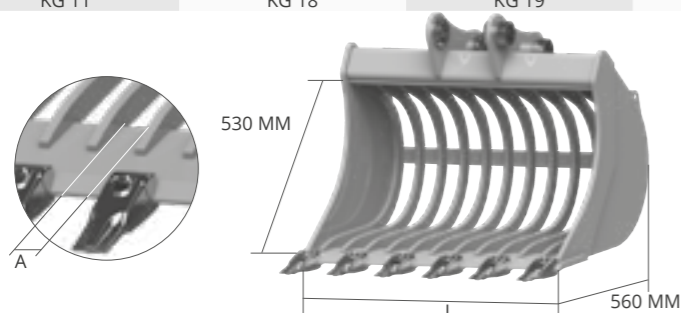
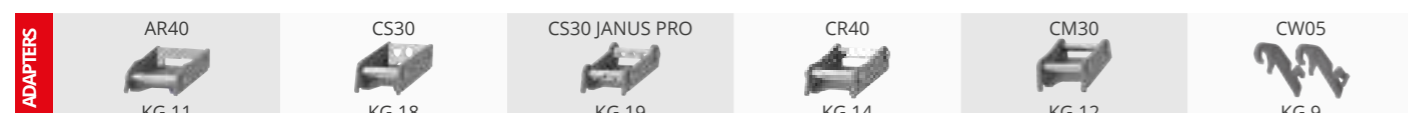

ACCESORIOS OPCIONALES

2
HOJA INFERIOR SOLDADA DE HB500

L MM	A MM	PESO KG*	CAP. SAE L	DIENTES N°	ADAPTERS
700	59	80	142	5	AF - AR - CS
					CR - CM
					CW - CS JANUS PRO
800	55	91	166	5	AF - AR - CS
					CR - CM
					CW - CS JANUS PRO
900	58	100	190	5	AF - AR - CS
					CR - CM
					CW - CS JANUS PRO

VE62 PESO MÁQUINA 4,0 - 5,0

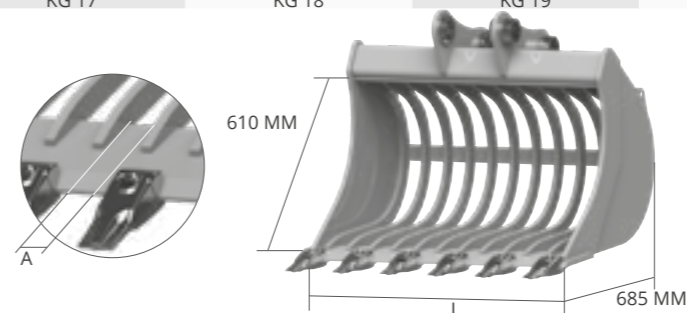
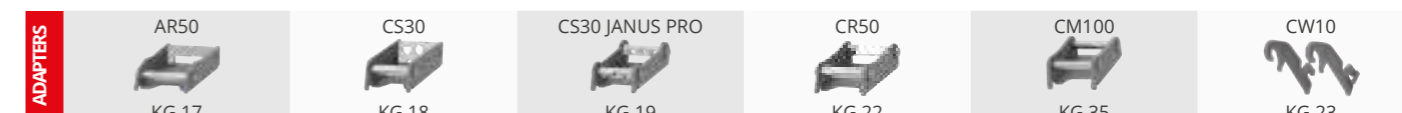

ACCESORIOS OPCIONALES

2
HOJA INFERIOR SOLDADA DE HB500

L MM	A MM	PESO KG*	CAP. SAE L	DIENTES N°	ADAPTERS
800	66	126	226	5	AF - AR - CS
					CR - CM
					CW - CS JANUS PRO
900	61	142	259	6	AF - AR - CS
					CR - CM
					CW - CS JANUS PRO
1000	63	153	292	6	AF - AR - CS
					CR - CM
					CW - CS JANUS PRO

* peso cazo sin enganches

* peso cazo sin enganches

VE67 PESO MÁQUINA 5,0 - 7,5

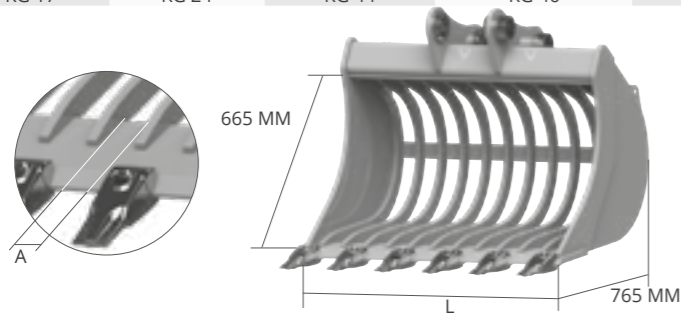
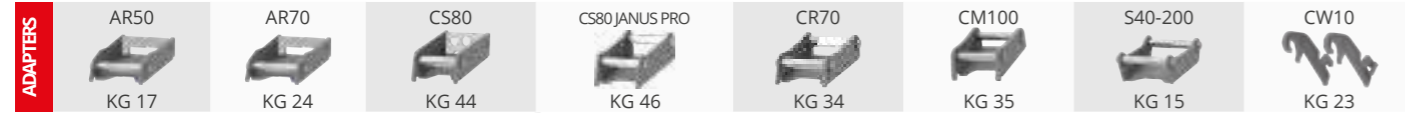

ACCESORIOS OPCIONALES

2
HOJA INFERIOR SOLDADA DE HB500

L MM	A MM	PESO KG*	CAP. SAE L	DIENTES N°	ADAPTERS
800	66	166	258	5	AF - AR - CS
					CR - CM
					CW - CS JANUS PRO
900	61	187	296	6	AF - AR - CS
					CR - CM
					CW - CS JANUS PRO
1000	63	202	335	6	AF - AR - CS
					CR - CM
					CW - CS JANUS PRO

VE73 PESO MÁQUINA 7,5 - 10,0

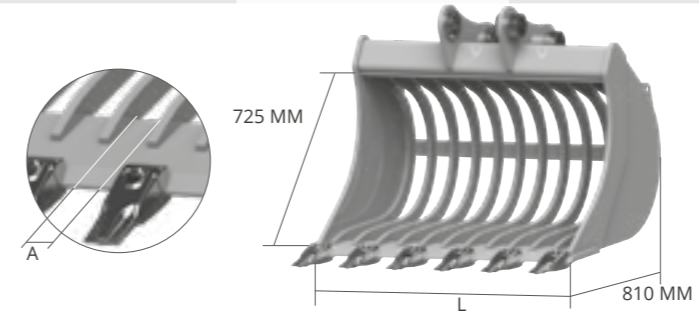

ACCESORIOS OPCIONALES

2
HOJA INFERIOR SOLDADA DE HB500

L MM	A MM	PESO KG*	CAP. SAE L	DIENTES N°	ADAPTERS
800	74	192	296	5	AF - CS
					CR - CM
					CW - CS JANUS PRO
900	67	216	340	5	AF - CS
					CR - CM
					CW - CS JANUS PRO
1000	69	234	384	5	AF - CS
					CR - CM
					CW - CS JANUS PRO

VE80 PESO MÁQUINA 10,0 - 12,0

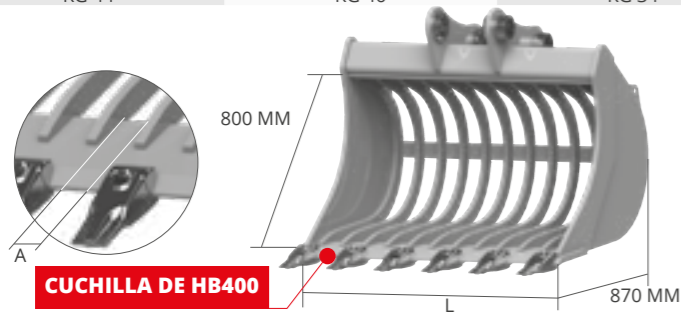

ACCESORIOS OPCIONALES

2
HOJA INFERIOR SOLDADA DE HB500

L MM	A MM	PESO KG*	CAP. SAE L	DIENTES N°	ADAPTERS
900	74	252	410	5	AF - CS
					CR - CM - CS JANUS PRO
					CW
1000	67	273	479	5	AF - CS
					CR - CM - CS JANUS PRO
					CW
1100	69	302	555	5	AF - CS
					CR - CM - CS JANUS PRO
					CW

VE85 MIDI PESO MÁQUINA 12,0 - 14,0

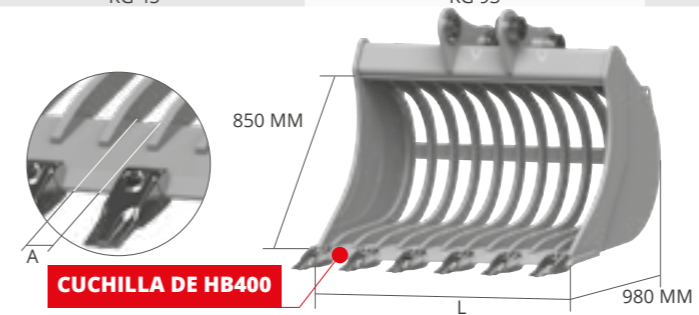
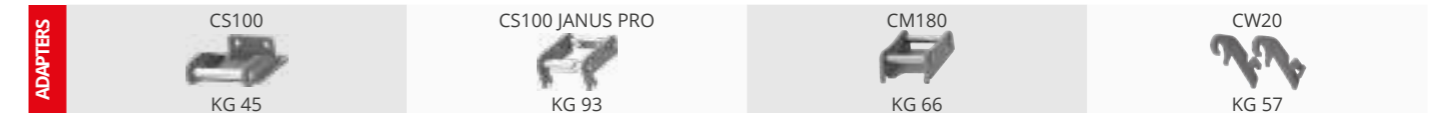

ACCESORIOS OPCIONALES

2
HOJA INFERIOR SOLDADA DE HB500

L MM	A MM	PESO KG*	CAP. SAE L	DIENTES N°	ADAPTERS
900	80	335	510	5	AF - CM
					CS - CW
					CS JANUS PRO
1000	80	363	584	5	AF - CM
					CS - CW
					CS JANUS PRO
1100	80	390	657	5	AF - CM
					CS - CW
					CS JANUS PRO
1200	80	418	730	6	AF - CM
					CS - CW
					CS JANUS PRO

* peso cazo sin enganches

* peso cazo sin enganches

VE92 GD EXCAVATOR PESO MÁQUINA 12,0 - 14,0

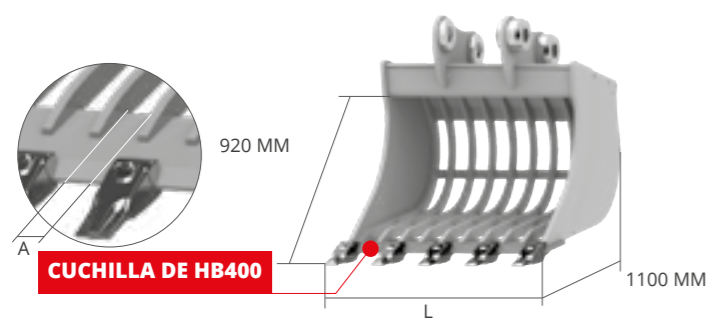
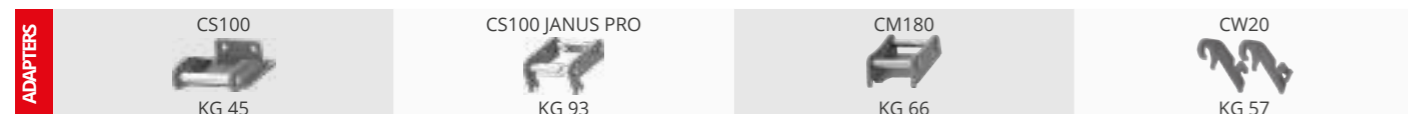

ACCESORIOS OPCIONALES

2
HOJA INFERIOR SOLDADA DE HB500

L MM	A MM	PESO KG*	CAP. SAE L	DIENTES N°	ADAPTERS
1200	80	431	783	5	AF - CM
					CS - CW
					CS JANUS PRO
1300	80	453	878	6	AF - CM
					CS - CW
					CS JANUS PRO
1400	80	475	973	6	AF - CM
					CS - CW
					CS JANUS PRO

VE100 GD PESO MÁQUINA 14,0 - 18,0

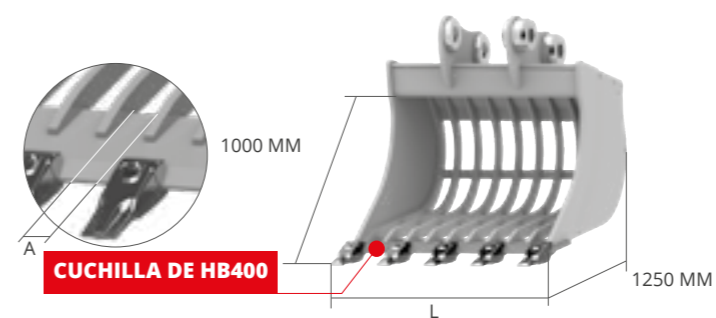
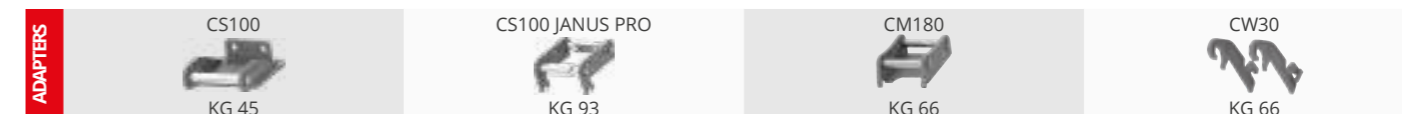

ACCESORIOS OPCIONALES

2
HOJA INFERIOR SOLDADA DE HB500

L MM	A MM	PESO KG*	CAP. SAE L	DIENTES N°	ADAPTERS
1200	100	587	909	5	AF - CM
					CS - CW
					CS JANUS PRO
1300	100	632	1004	6	AF - CM
					CS - CW
					CS JANUS PRO
1400	100	677	1108	6	AF - CM
					CS - CW
					CS JANUS PRO

VE110 GD PESO MÁQUINA 18,0 - 22,0

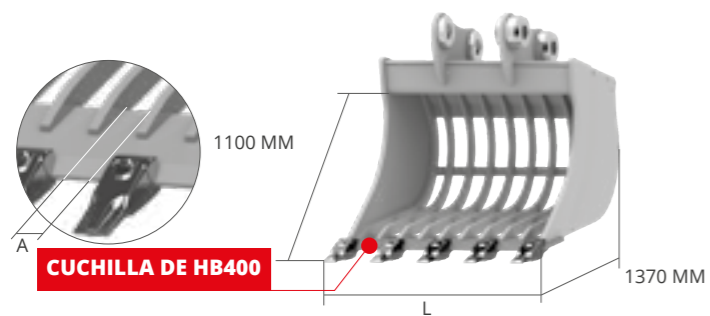
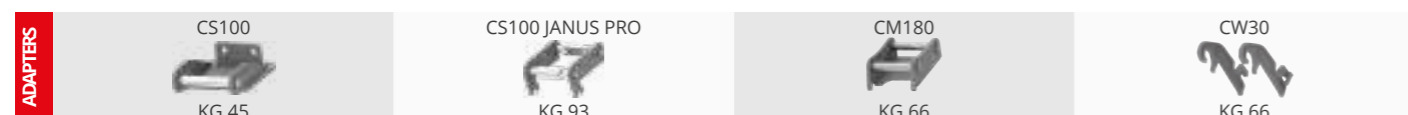

ACCESORIOS OPCIONALES

2
HOJA INFERIOR SOLDADA DE HB500

L MM	A MM	PESO KG*	CAP. SAE L	DIENTES N°	ADAPTERS
1200	100	691	1064	5	AF - CM
					CS - CW
					CS JANUS PRO
1300	100	741	1173	6	AF - CM
					CS - CW
					CS JANUS PRO
1400	100	791	1288	6	AF - CM
					CS - CW
					CS JANUS PRO

* peso cazo sin enganches

* peso cazo sin enganches