



DER GITTERLÖFFEL DIENT ZUM SORTIEREN VON STEINEN USW. KLEINERES MATERIAL, SAND UND ERDE FALLEN BEIM SCHÜTTELN DES AUSLEGERS DURCH DAS GITTER ZUM BODEN. AUF ANFRAGE KÖNNEN AUCH LÖFFEL MIT ABWEICHENDEN STEGABSTÄNDEN GELIEFERT WERDEN.



STANDARD TECHNISCHE DATEN

1 ZÄHNE DC ZÄHNE DTE

ZUBEHÖR

2 **UNTERSCHWEISSMESSER AUS HB500 (KEINE ZÄHNE)**

EMPFOLHEN FÜR BESONDERS ABRASIVE BÖDEN.

MOD.	VE38	VE45	VE53	VE62	VE67	VE73	VE80	MIDI	EXCAVATOR		
								VE85	VE92 GD	VE100 GD	VE110 GD
TONS	0,6 - 1,8	1,8 - 2,5	2,5 - 4,0	4,0 - 5,0	5,0 - 7,5	7,5 - 10,0	10,0 - 12,0	12,0 - 14,0	12,0 - 14,0	14,0 - 18,0	18,0 - 22,0

VE38 MASCHINENGEWICHT 0,6 - 1,8

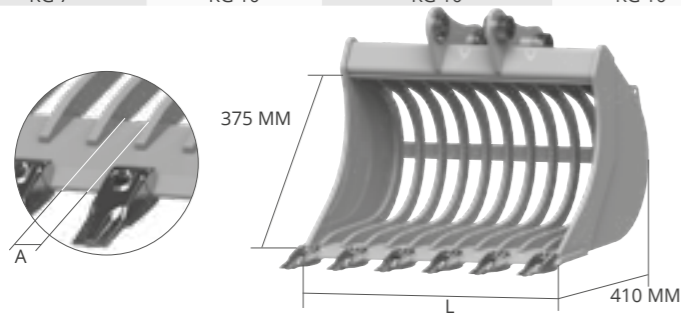

ZUBEHÖR

2
UNTERSCHWEISS-
MESSER AUS HB500

L A GEWICHT KAP. SAE ZÄHNE
MM MM KG* L N° ADAPTERS

L	A	GEWICHT	KAP.	SAE	ZÄHNE	ADAPTERS
MM	MM	KG*	L	L	N°	
500	54	31	49	4	4	AF - AR - CS
						CR - CM
						CW - CS JANUS PRO
600	51	35	61	4	4	AF - AR - CS
						CR - CM
						CW - CS JANUS PRO
700	55	42	74	5	5	AF - AR - CS
						CR - CM
						CW - CS JANUS PRO

VE45 MASCHINENGEWICHT 1,8 - 2,5

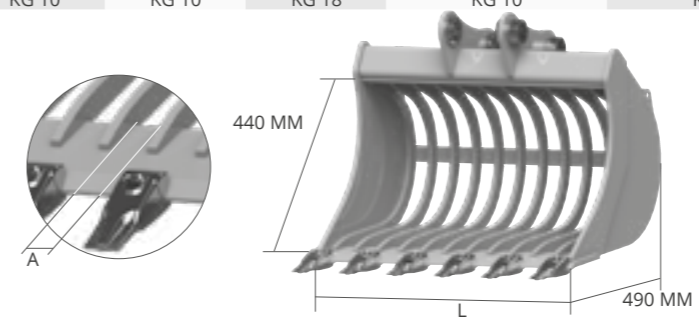

ZUBEHÖR

2
UNTERSCHWEISS-
MESSER AUS HB500

L A GEWICHT KAP. SAE ZÄHNE
MM MM KG* L N° ADAPTERS

L	A	GEWICHT	KAP.	SAE	ZÄHNE	ADAPTERS
MM	MM	KG*	L	L	N°	
600	55	51	79	4	4	AF - AR - CS
						CR - CM
						CW - CS JANUS PRO
700	59	57	95	5	5	AF - AR - CS
						CR - CM
						CW - CS JANUS PRO
800	55	64	111	5	5	AF - AR - CS
						CR - CM
						CW - CS JANUS PRO

VE53 MASCHINENGEWICHT 2,5 - 4,0

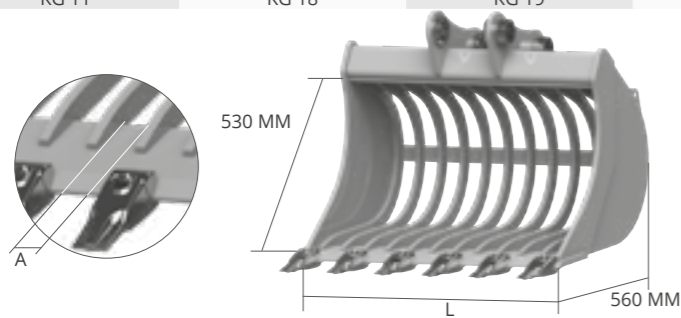
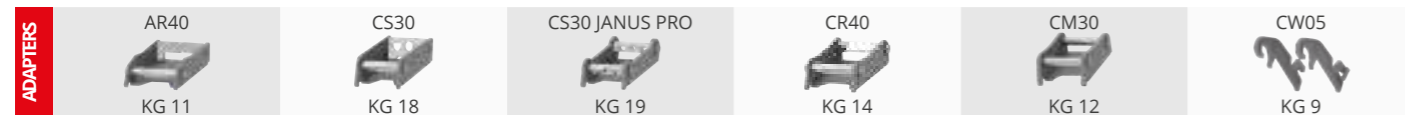

ZUBEHÖR

2
UNTERSCHWEISS-
MESSER AUS HB500

L A GEWICHT KAP. SAE ZÄHNE
MM MM KG* L N° ADAPTERS

L	A	GEWICHT	KAP.	SAE	ZÄHNE	ADAPTERS
MM	MM	KG*	L	L	N°	
700	59	80	142	5	5	AF - AR - CS
						CR - CM
						CW - CS JANUS PRO
800	55	91	166	5	5	AF - AR - CS
						CR - CM
						CW - CS JANUS PRO
900	58	100	190	5	5	AF - AR - CS
						CR - CM
						CW - CS JANUS PRO

VE62 MASCHINENGEWICHT 4,0 - 5,0

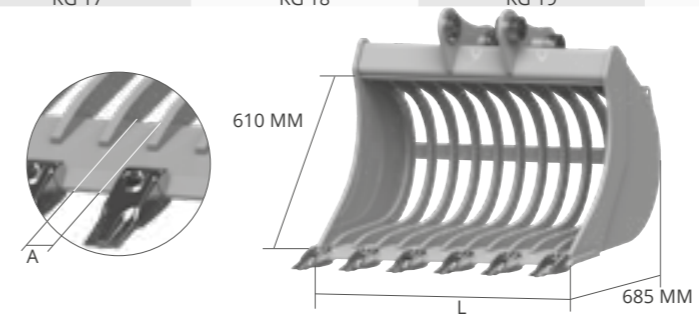
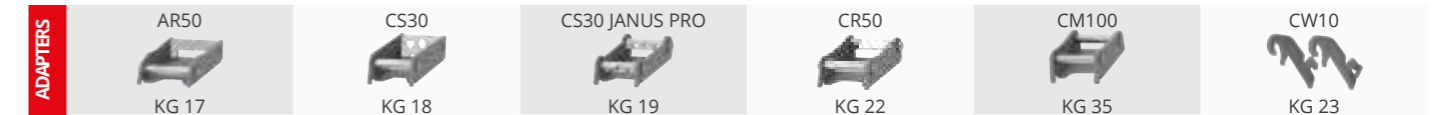

ZUBEHÖR

2
UNTERSCHWEISS-
MESSER AUS HB500

L A GEWICHT KAP. SAE ZÄHNE
MM MM KG* L N° ADAPTERS

L	A	GEWICHT	KAP.	SAE	ZÄHNE	ADAPTERS
MM	MM	KG*	L	L	N°	
800	66	126	226	5	5	AF - AR - CS
						CR - CM
						CW - CS JANUS PRO
900	61	142	259	6	6	AF - AR - CS
						CR - CM
						CW - CS JANUS PRO
1000	63	153	292	6	6	AF - AR - CS
						CR - CM
						CW - CS JANUS PRO

* Gewicht des Löffel ohne Anbauteile und Zähne

* Gewicht des Löffel ohne Anbauteile und Zähne

VE67 MASCHINENGEWICHT 5,0 - 7,5

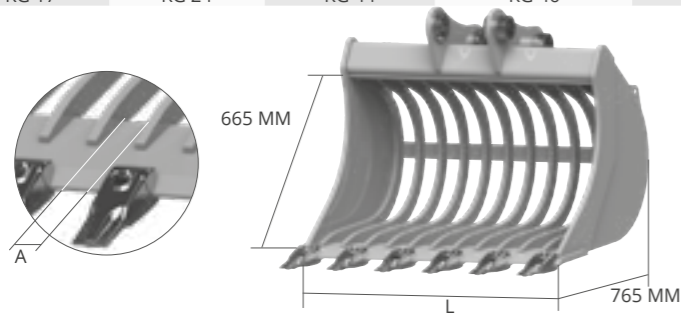
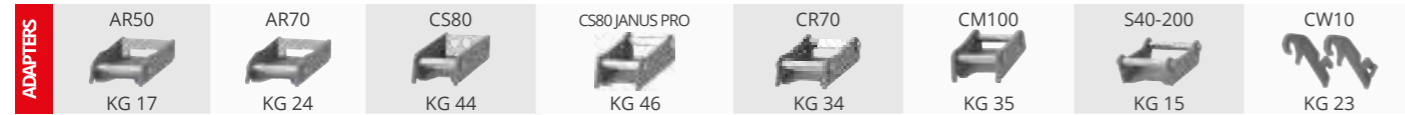

ZUBEHÖR

2
UNTERSCHWEISS-
MESSER AUS HB500

L MM	A MM	GEWICHT KG*	KAP. L	SAE N°	ZÄHNE N°	ADAPTERS
800	66	166	258	5		AF - AR - CS
						CR - CM
						CW - CS JANUS PRO
900	61	187	296	6		AF - AR - CS
						CR - CM
						CW - CS JANUS PRO
1000	63	202	335	6		AF - AR - CS
						CR - CM
						CW - CS JANUS PRO

VE73 MASCHINENGEWICHT 7,5 - 10,0

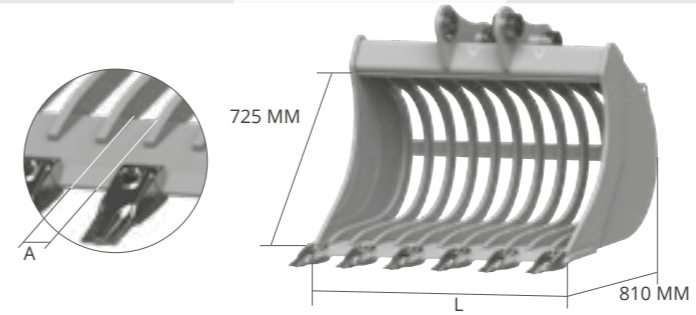

ZUBEHÖR

2
UNTERSCHWEISS-
MESSER AUS HB500

L MM	A MM	GEWICHT KG*	KAP. L	SAE N°	ZÄHNE N°	ADAPTERS
800	74	192	296	5		AF - CS
						CR - CM
						CW - CS JANUS PRO
900	67	216	340	5		AF - CS
						CR - CM
						CW - CS JANUS PRO
1000	69	234	384	5		AF - CS
						CR - CM
						CW - CS JANUS PRO

VE80 MASCHINENGEWICHT 10,0 - 12,0

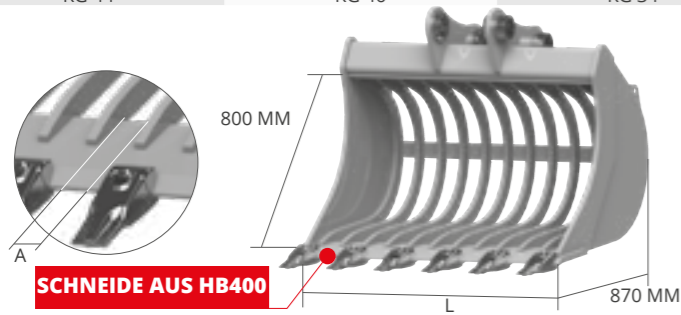

ZUBEHÖR

2
UNTERSCHWEISS-
MESSER AUS HB500

L MM	A MM	GEWICHT KG*	KAP. L	SAE N°	ZÄHNE N°	ADAPTERS
900	74	252	410	5		AF - CS
						CR - CM - CS JANUS PRO
						CW
1000	67	273	479	5		AF - CS
						CR - CM - CS JANUS PRO
						CW
1100	69	302	555	5		AF - CS
						CR - CM - CS JANUS PRO
						CW

VE85 MIDI MASCHINENGEWICHT 12,0 - 14,0

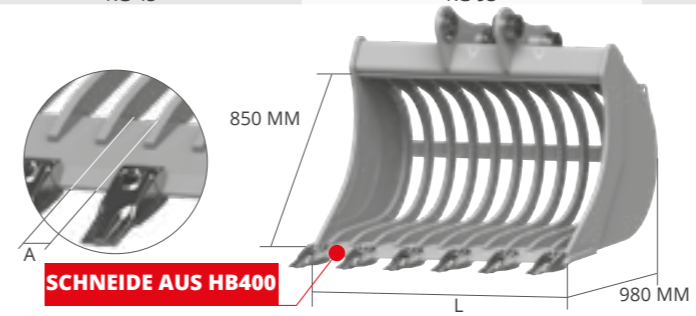
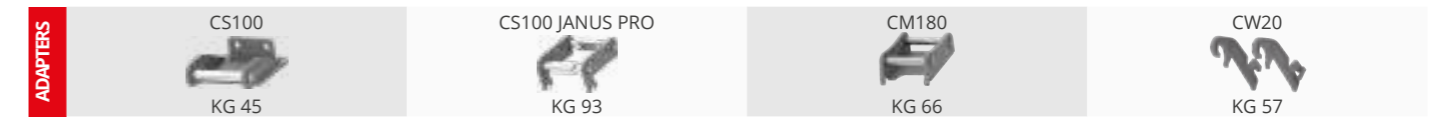

ZUBEHÖR

2
UNTERSCHWEISS-
MESSER AUS HB500

L MM	A MM	GEWICHT KG*	KAP. L	SAE N°	ZÄHNE N°	ADAPTERS
900	80	335	510	5		AF - CM
						CS - CW
						CS JANUS PRO
1000	80	363	584	5		AF - CM
						CS - CW
						CS JANUS PRO
1100	80	390	657	5		AF - CM
						CS - CW
						CS JANUS PRO
1200	80	418	730	6		AF - CM
						CS - CW
						CS JANUS PRO

* Gewicht des Löffel ohne Anbauteile und Zähne

* Gewicht des Löffel ohne Anbauteile und Zähne

VE92 GD EXCAVATOR MASCHINENGEWICHT 12,0 - 14,0

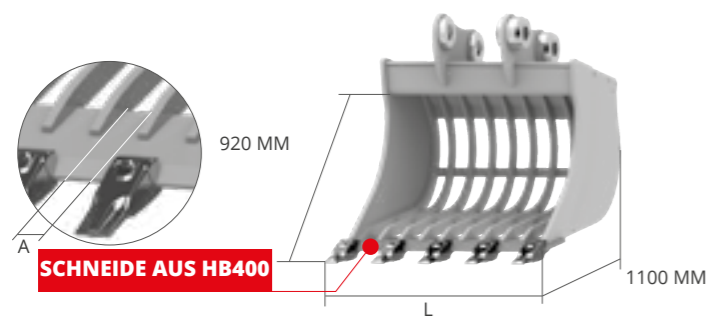
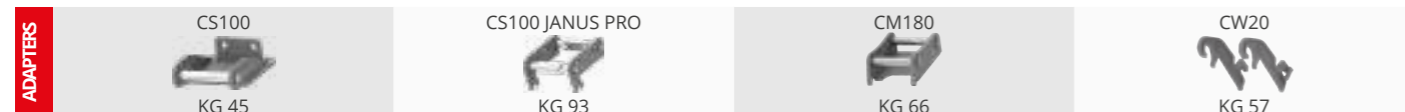

ZUBEHÖR

2
UNTERSCHWEISS-
MESSER AUS HB500

L MM	A MM	GEWICHT KG*	KAP. SAE L	ZÄHNE N°	ADAPTERS
1200	80	431	783	5	AF - CM
					CS - CW
					CS JANUS PRO
1300	80	453	878	6	AF - CM
					CS - CW
					CS JANUS PRO
1400	80	475	973	6	AF - CM
					CS - CW
					CS JANUS PRO

VE100 GD MASCHINENGEWICHT 14,0 - 18,0

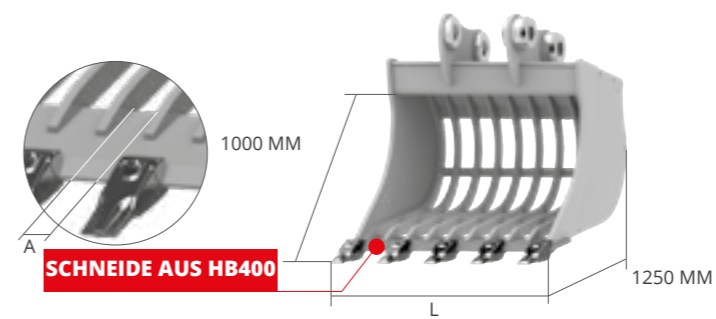
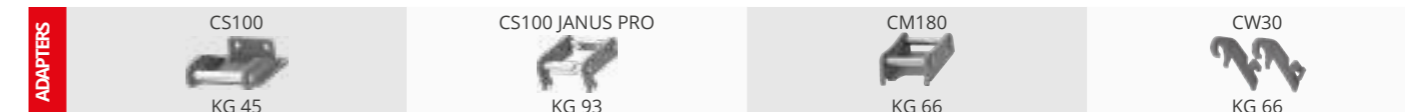

ZUBEHÖR

2
UNTERSCHWEISS-
MESSER AUS HB500

L MM	A MM	GEWICHT KG*	KAP. SAE L	ZÄHNE N°	ADAPTERS
1200	100	587	909	5	AF - CM
					CS - CW
					CS JANUS PRO
1300	100	632	1004	6	AF - CM
					CS - CW
					CS JANUS PRO
1400	100	677	1108	6	AF - CM
					CS - CW
					CS JANUS PRO

VE110 GD MASCHINENGEWICHT 18,0 - 22,0

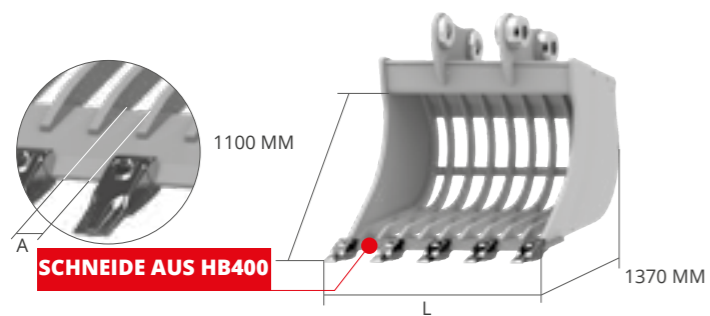
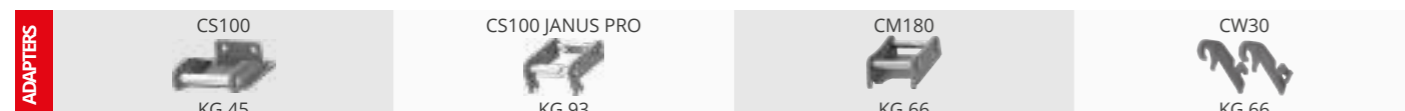

ZUBEHÖR

2
UNTERSCHWEISS-
MESSER AUS HB500

L MM	A MM	GEWICHT KG*	KAP. SAE L	ZÄHNE N°	ADAPTERS
1200	100	691	1064	5	AF - CM
					CS - CW
					CS JANUS PRO
1300	100	741	1173	6	AF - CM
					CS - CW
					CS JANUS PRO
1400	100	791	1288	6	AF - CM
					CS - CW
					CS JANUS PRO

* Gewicht des Löffel ohne Anbauteile und Zähne

* Gewicht des Löffel ohne Anbauteile und Zähne