

SA FORME ALLONGÉE PERMET DE DÉCHARGEMENT DE MATÉRIAUX ARGILEUX ET MOUILLÉS. UTILISÉ POUR L'ENTRETIEN ET LE NIVELAGE DE ROUTES, FOSSÉS ET TALUS. LAME EN HB400.

MOD.	SPN28	SPN35	SPN41	SPN44	SPN50	SPN55	SPN66
TONS	0,6 - 1,2	1,2 - 1,8	1,8 - 2,5	2,5 - 4,0	4,0 - 6,0	6,0 - 7,5	7,5 - 12,0

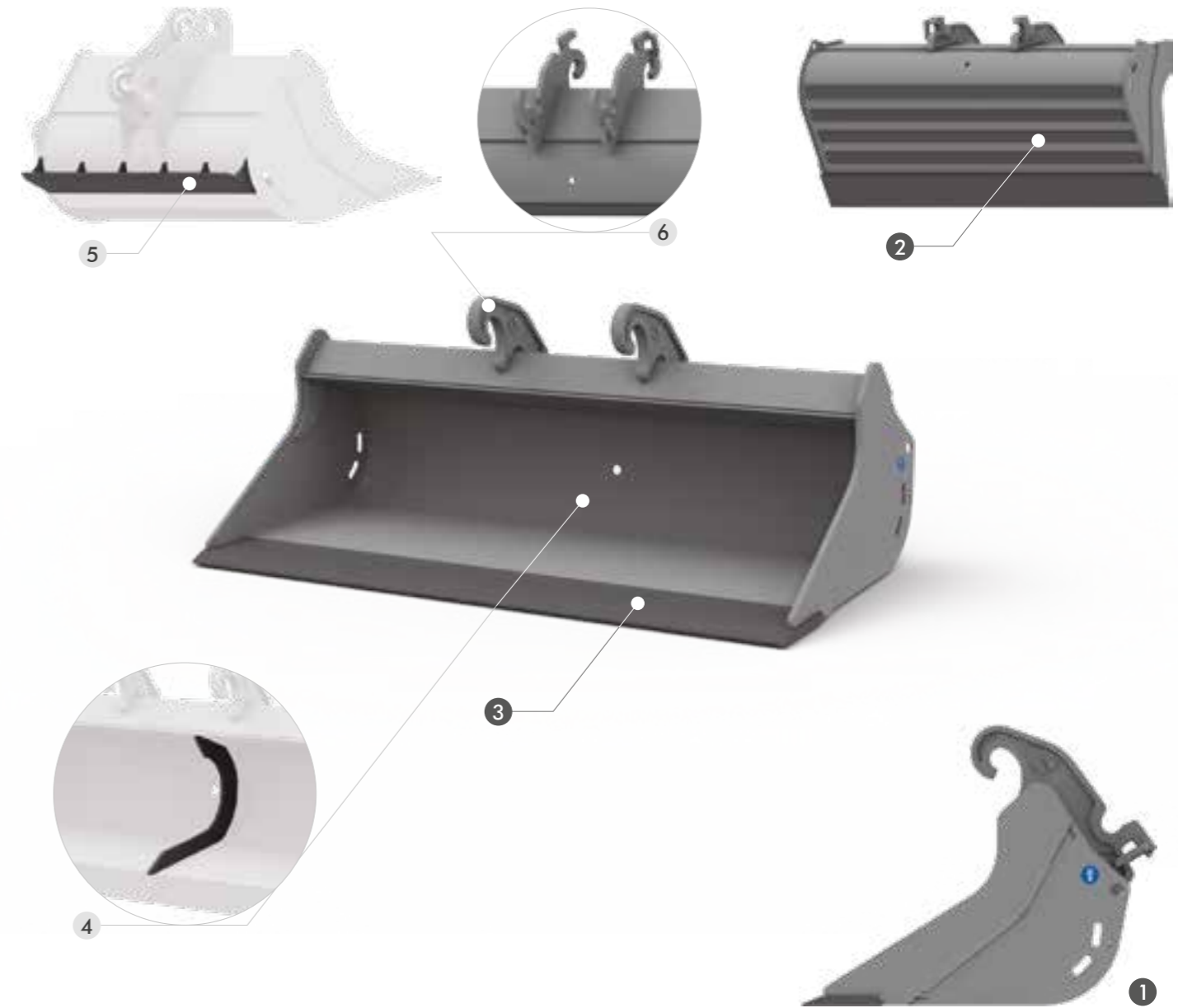

ADAPTERS



CHARACTERISTIQUES TECHNIQUES STANDARD

- 1 PROFIL ALLONGÉ**
- 2 BANDES DE RENFORCEMENT**
LES BANDES DE RENFORCEMENT HORIZONTALES PROTÈGENT LE FOND EN AUGMENTANT SA RÉSISTANCE À L'USURE.
- 3 LAME EN HB400**

EN OPTION

- 4 VIRGULE**
GARANTIT UNE RÉSISTANCE ACCRUE À LA STRUCTURE. CONSEILLÉE POUR LES GODETS AVEC UNE LARGEUR ÉGALE OU SUPÉRIEURE À 1400 MM.
- 5 LAME DORSALE**
AVEC LE BRAS MACHINE EN POSITION PLIÉE, ELLE PERMET LA FINITION UNIFORME DES SURFACES.
- 6 VERSION RÉVERSIBLE CW**
CET ADAPTEUR PERMET DE RENDRE LE GODET RÉVERSIBLE.

SPN28 POIDS MACHINE 0,6 - 1,2

ADAPTERS

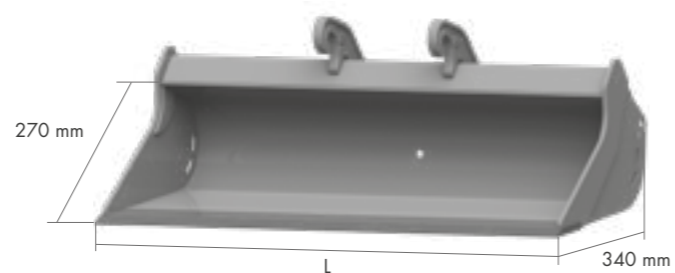

EN OPTION

5	6
Lame dorsale	Version réversible CW

L mm	POIDS Kg*	CAP. SAE l	
600	27	35	AF
600	27	35	CW
700	31	41	AF
700	31	41	CW
800	35	47	AF
800	35	47	CW

SPN35 POIDS MACHINE 1,2 - 1,8

ADAPTERS

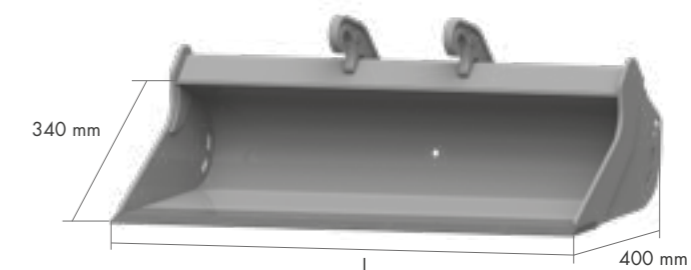

EN OPTION

5	6
Lame dorsale	Version réversible CW

L mm	POIDS Kg*	CAP. SAE l	
800	43	77	AF
800	43	77	CW
900	48	89	AF
900	48	89	CW
1000	53	99	AF
1000	53	99	CW

SPN41 POIDS MACHINE 1,8 - 2,5

ADAPTERS

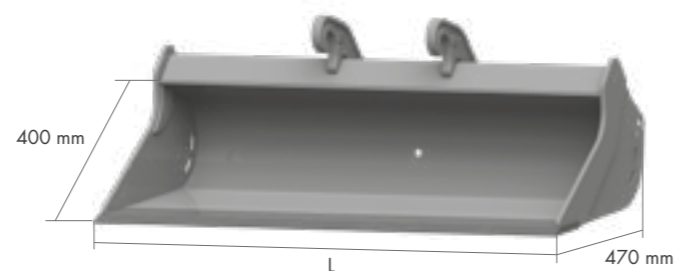
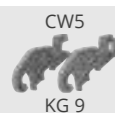

EN OPTION

5	6
Lame dorsale	Version réversible CW

L mm	POIDS Kg*	CAP. SAE l	
900	65	95	AF
900	65	95	CW
1000	72	107	AF
1000	72	107	CW
1100	78	119	AF
1100	78	119	CW
1200	85	131	AF
1200	85	131	CW

SPN44 POIDS MACHINE 2,5 - 4,0

ADAPTERS

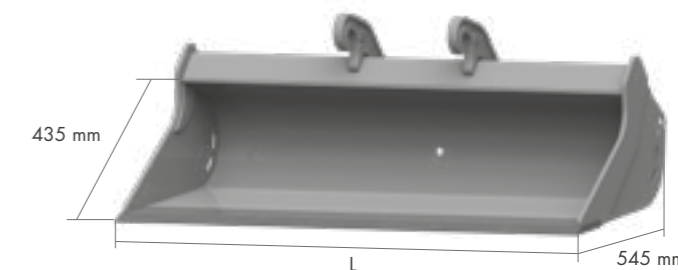

EN OPTION

5	6
Lame dorsale	Version réversible CW

L mm	POIDS Kg*	CAP. SAE l	
1000	93	149	AF
1000	93	149	CW
1100	101	166	AF
1100	101	166	CW
1200	109	184	AF
1200	109	184	CW

* poids cuve sans attache



* poids cuve sans attache

SPN50 POIDS MACHINE 4,0 - 6,0

ADAPTERS

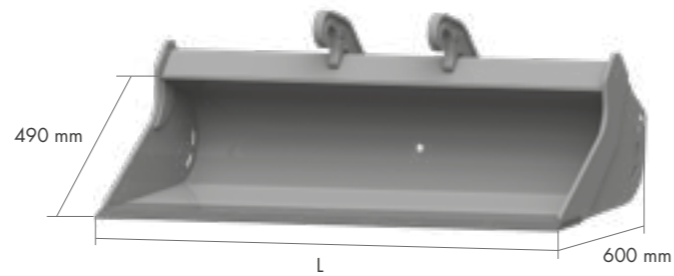
CW10
KG 23



L mm	POIDS Kg*	CAP. SAE l	 
1000	105	192	AF
1000	105	192	CW
1100	115	215	AF
1100	115	215	CW
1200	124	238	AF
1200	124	238	CW
1300	134	261	AF
1300	134	261	CW
1400	143	284	AF
1400	143	284	CW

EN OPTION



4	5	6
Virgule	Lame dorsale	Version réversible CW

SPN55 POIDS MACHINE 6,0 - 7,5

ADAPTERS

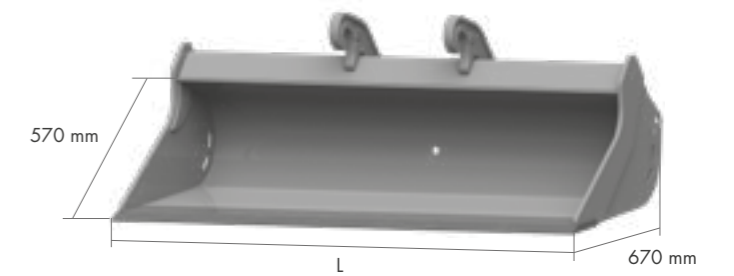
CW10
KG 23



L mm	POIDS Kg*	CAP. SAE l	 
1200	164	283	AF
1200	164	283	CW
1300	177	311	AF
1300	177	311	CW
1400	189	341	AF
1400	189	341	CW
1500	202	368	AF
1500	202	368	CW
1600	214	396	AF
1600	214	396	CW

EN OPTION



4	5	6
Virgule	Lame dorsale	Version réversible CW

SPN66 POIDS MACHINE 7,5 - 12,0

ADAPTERS

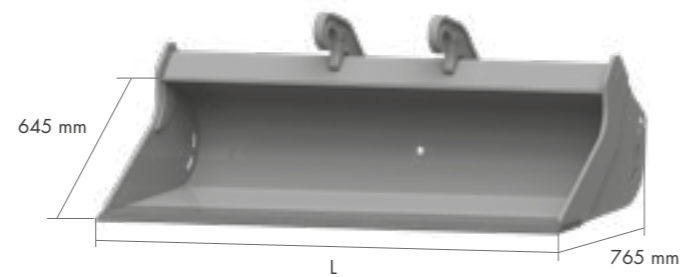
CW10
KG 23



L mm	POIDS Kg*	CAP. SAE l	 
1400	231	459	AF
1400	231	459	CW
1500	246	498	AF
1500	246	498	CW
1600	261	537	AF
1600	261	537	CW
1700	276	575	AF
1700	276	575	CW
1800	291	614	AF
1800	291	614	CW

EN OPTION

4	5	6
Virgule	Lame dorsale	Version réversible CW

* poids cuve sans attache

* poids cuve sans attache