

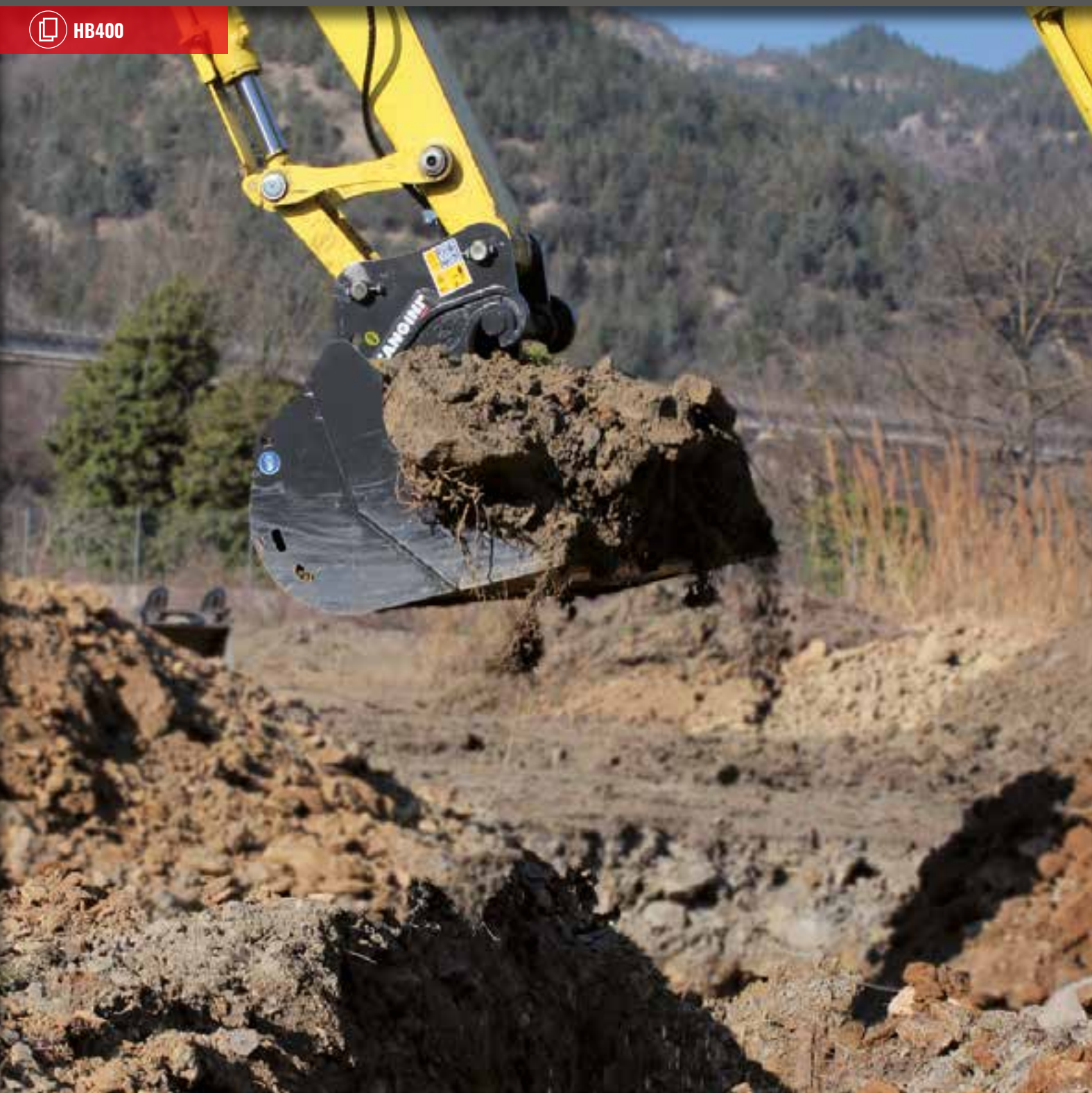

HB400



ITS ELONGATED PROFILE SIMPLIFIES THE DISCHARGE OF LOAMY AND WET MATERIALS. USED TO CLEAN AND LEVEL STREETS, DITCHES AND DIKES. THE HOLLAND BUCKET IS EQUIPPED WITH HB400 BLADE.



ADAPTERS

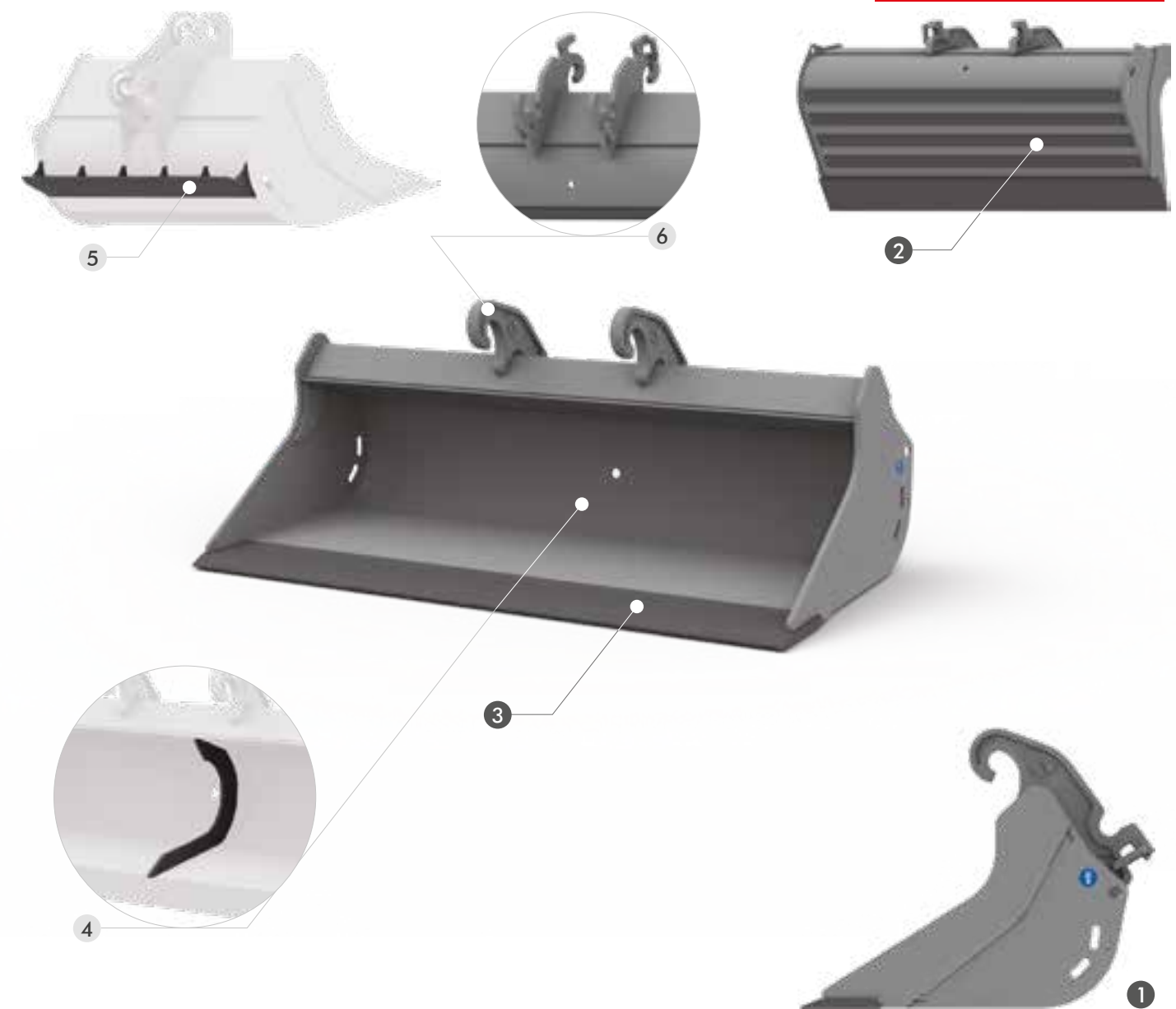

STANDARD TECHNICAL FEATURES

- 1 ELONGATED PROFILE**
- 2 REINFORCING STRIPS**
THE HORIZONTAL REINFORCING STRIPS ON THE BUCKET'S REAR AND BOTTOM PROTECT THE BUCKET FROM WEAR AND INCREASE ITS RESISTANCE.
- 3 HB400 BLADE**

OPTIONAL

- 4 BEZEL**
IT ENSURES A HIGHER STRUCTURAL RESISTANCE TO BUCKETS WHOSE FRAME IS 1400 MM (55 IN) WIDE OR MORE.
- 5 REAR RAZOR**
WHEN THE MACHINE'S ARM IS KEPT CLOSED, IT ALLOWS TO FINISH SURFACES EVENLY.
- 6 CW REVERSIBLE VERSION**
THIS ADAPTER MAKES THE BUCKET REVERSIBLE.

MOD.	SPN28	SPN35	SPN41	SPN44	SPN50	SPN55	SPN66
Tons (lb)	0,6 - 1,2 (1323 - 2646)	1,2 - 1,8 (2646 - 3968)	1,8 - 2,5 (3968 - 5512)	2,5 - 4,0 (5512 - 8818)	4,0 - 6,0 (8818 - 13228)	6,0 - 7,5 (13228 - 16535)	7,5 - 12,0 (16535 - 26455)

SPN28 MACHINE WEIGHT 0,6 - 1,2 t (1323 - 2646 lb)

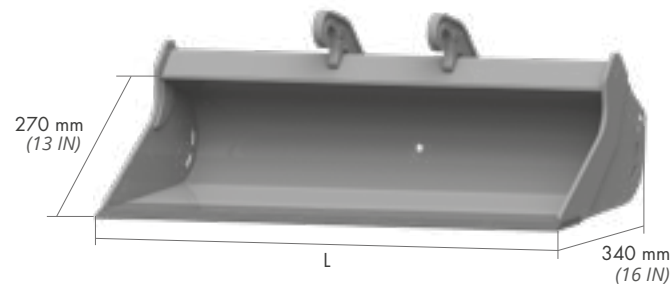

OPTIONAL

5	6
Rear razor	CW reversible

L mm (in)	WEIGHT Kg* (lb*)	CAP. SAE l (gal)	
600 (24)	27 (60)	35 (9,2)	AF
600 (24)	27 (60)	35 (9,2)	CW
700 (28)	31 (68)	41 (10,8)	AF
700 (28)	31 (68)	41 (10,8)	CW
800 (31)	35 (77)	47 (12,4)	AF
800 (31)	35 (77)	47 (12,4)	CW

SPN35 MACHINE WEIGHT 1,2 - 1,8 t (2646 - 3968 lb)

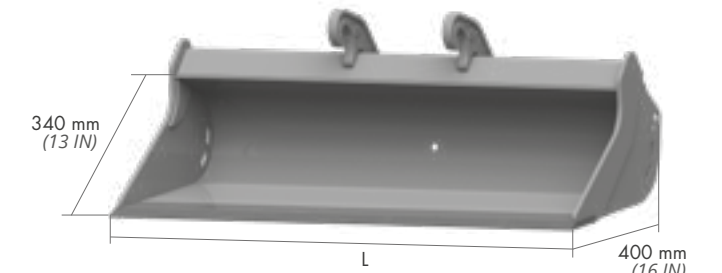

OPTIONAL

5	6
Rear razor	CW reversible

L mm (in)	WEIGHT Kg* (lb*)	CAP. SAE l (gal)	
800 (31)	43 (95)	77 (20,3)	AF
800 (31)	43 (95)	77 (20,3)	CW
900 (35)	48 (106)	89 (23,5)	AF
900 (35)	48 (106)	89 (23,5)	CW
1000 (39)	53 (117)	99 (26,2)	AF
1000 (39)	53 (117)	99 (26,2)	CW

SPN41 MACHINE WEIGHT 1,8 - 2,5 t (3968 - 5512 lb)

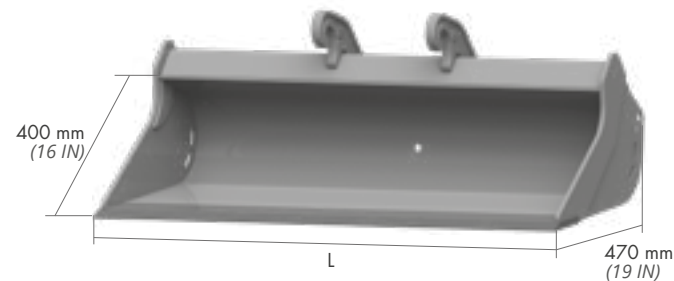
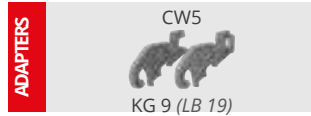

OPTIONAL

5	6
Rear razor	CW reversible

L mm (in)	WEIGHT Kg* (lb*)	CAP. SAE l (gal)	
900 (35)	65 (143)	95 (25,1)	AF
900 (35)	65 (143)	95 (25,1)	CW
1000 (39)	72 (159)	107 (28,3)	AF
1000 (39)	72 (159)	107 (28,3)	CW
1100 (43)	78 (172)	119 (31,4)	AF
1100 (43)	78 (172)	119 (31,4)	CW
1200 (47)	85 (187)	131 (34,6)	AF
1200 (47)	85 (187)	131 (34,6)	CW

SPN44 MACHINE WEIGHT 2,5 - 4,0 t (5512 - 8818 lb)

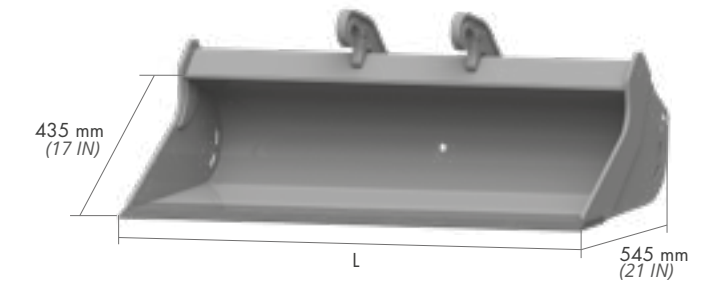

OPTIONAL

5	6
Rear razor	CW reversible

L mm (in)	WEIGHT Kg* (lb*)	CAP. SAE l (gal)	
1000 (39)	93 (205)	149 (39,4)	AF
1000 (39)	93 (205)	149 (39,4)	CW
1100 (43)	101 (223)	166 (43,9)	AF
1100 (43)	101 (223)	166 (43,9)	CW
1200 (47)	109 (240)	184 (48,6)	AF
1200 (47)	109 (240)	184 (48,6)	CW

* weight of the tank excluding attachment



* weight of the tank excluding attachment

SPN50 MACHINE WEIGHT 4,0 - 6,0 t (8818 - 13228 lb)

ADAPTERS

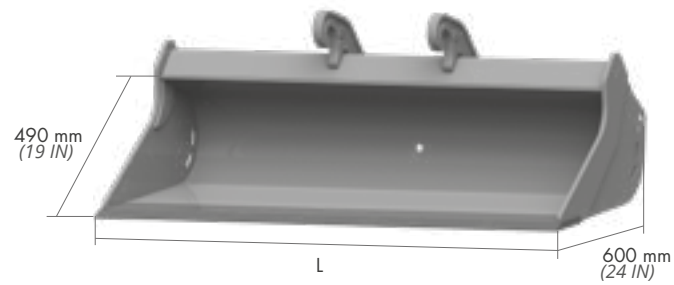
CW10
KG 23 (LB 50)



L mm (in)	WEIGHT Kg* (lb*)	CAP. SAE l (gal)	 
1000 (39)	105 (231)	192 (50,7)	AF
1000 (39)	105 (231)	192 (50,7)	CW
1100 (43)	115 (254)	215 (56,8)	AF
1100 (43)	115 (254)	215 (56,8)	CW
1200 (47)	124 (273)	238 (62,9)	AF
1200 (47)	124 (273)	238 (62,9)	CW
1300 (51)	134 (295)	261 (68,9)	AF
1300 (51)	134 (295)	261 (68,9)	CW
1400 (55)	143 (315)	284 (75,0)	AF
1400 (55)	143 (315)	284 (75,0)	CW

OPTIONAL



4	5	6
Bezel	Rear razor	CW reversible

SPN55 MACHINE WEIGHT 6,0 - 7,5 t (13228 - 16535 lb)

ADAPTERS

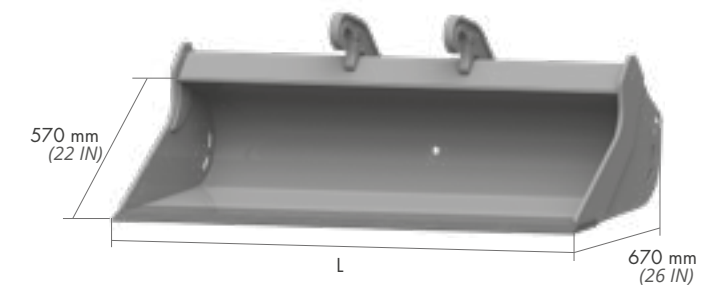
CW10
KG 23 (LB 50)



L mm (in)	WEIGHT Kg* (lb*)	CAP. SAE l (gal)	 
1200 (47)	164 (362)	283 (78,4)	AF
1200 (47)	164 (362)	283 (78,4)	CW
1300 (51)	177 (390)	311 (82,2)	AF
1300 (51)	177 (390)	311 (82,2)	CW
1400 (55)	189 (417)	341 (90,1)	AF
1400 (55)	189 (417)	341 (90,1)	CW
1500 (59)	202 (445)	368 (97,2)	AF
1500 (59)	202 (445)	368 (97,2)	CW
1600 (63)	214 (472)	396 (104,6)	AF
1600 (63)	214 (472)	396 (104,6)	CW

OPTIONAL



4	5	6
Bezel	Rear razor	CW reversible

SPN66 MACHINE WEIGHT 7,5 - 12,0 t (16535 - 26455 lb)

ADAPTERS

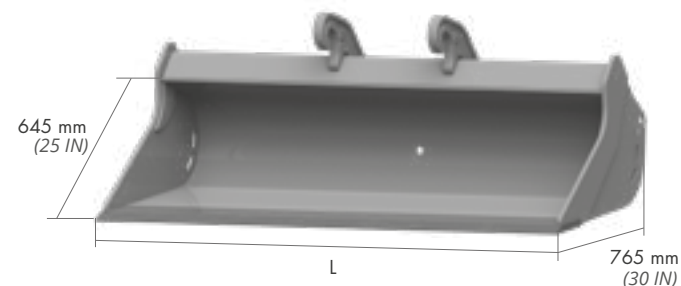
CW10
KG 23 (LB 50)



L mm (in)	WEIGHT Kg* (lb*)	CAP. SAE l (gal)	 
1400 (55)	231 (509)	459 (121,3)	AF
1400 (55)	231 (509)	459 (121,3)	CW
1500 (59)	246 (542)	498 (131,6)	AF
1500 (59)	246 (542)	498 (131,6)	CW
1600 (63)	261 (575)	537 (141,9)	AF
1600 (63)	261 (575)	537 (141,9)	CW
1700 (67)	276 (608)	575 (151,9)	AF
1700 (67)	276 (608)	575 (151,9)	CW
1800 (71)	291 (642)	614 (162,2)	AF
1800 (71)	291 (642)	614 (162,2)	CW

OPTIONAL

4	5	6
Bezel	Rear razor	CW reversible

* weight of the tank excluding attachment

* weight of the tank excluding attachment