

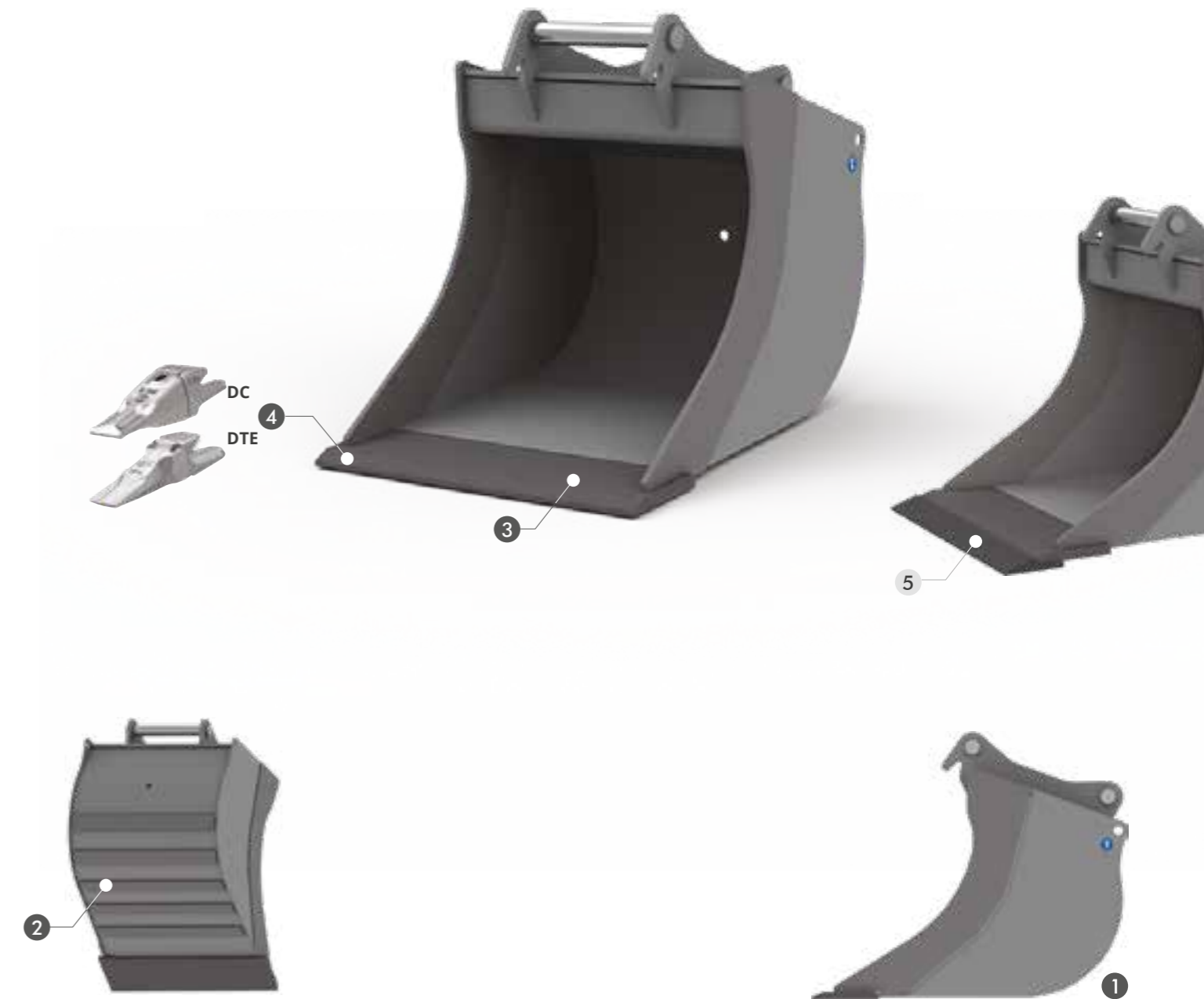

SEINE LANGGEZOGENE FORM VERHINDERT, DASS ERDE AN DEN SEITENWÄNDEN DES LÖFFELS HAFTET, WAS DEN AUSHUB VON TONIGEM UND FEUCHTEM ERDREICH ERLEICHTERT. SCHNEIDE AUS HB400 FÜR HÖHERE VERSCHLEISSFESTIGKEIT.

MOD.	MIDI EXCAVATOR											
	SCS 35GD	SCS 40GD	SCS 48GD	SCS 60GD	SCS 67GD	SCS 71GD	SCS 75GD	SCS 80GD	SCS 85GD	SCS 92GD	SCS 100GD	SCS 110GD
TONS	0,8 - 1,5	1,5 - 2,0	2,0 - 3,0	3,0 - 4,0	4,0 - 6,0	6,0 - 7,5	7,5 - 9,0	9,0 - 12,0	12,0 - 14,0	12,0 - 14,0	14,0 - 18,0	18,0 - 22,0



STANDARD TECHNISCHE DATEN

1 LANGGEZOGENES PROFIL DOPPELTE

2 VERSTÄRKTER VERSCHLEISS-SCHUTZ

DIE WAAGERECHTEN VERSTÄRKUNGEN BIETEN OPTIMALEN VERSCHLEISSSCHUTZ UND SCHÜTZEN DIE STRUKTUR.

3 SCHNEIDE AUS HB400

4 ZÄHNE DC ZÄHNE DTE

ZUBEHÖR

5 UNTERSCHWEISSMESSER AUS HB500

EMPFOHLEN FÜR BESONDERS ABRASIVE BÖDEN.

SCS35 GD MASCHINENGEWICHT 0,8 - 1,5

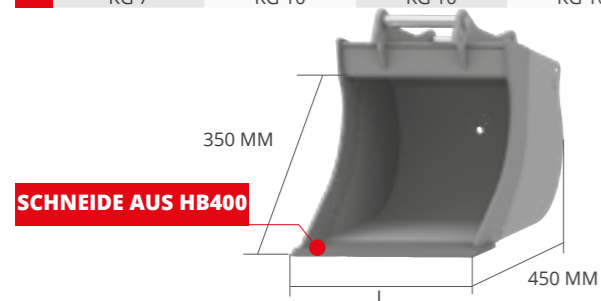

L MM	GEWICHT KG*	KAP. SAE L	ZÄHNE N°	ADAPTERS
250	17	25	3	AF - AR - CS
				CR - S - CM
				CW - CS JANUS PRO
300	20	30	3	AF - AR - CS
				CR - S - CM
				CW - CS JANUS PRO
400	26	42	3	AF - AR - CS
				CR - S - CM
				CW - CS JANUS PRO
500	31	54	4	AF - AR - CS
				CR - S - CM
				CW - CS JANUS PRO

ZUBEHÖR

5
UNTERSCHWEISS-
MESSER AUS HB500

SCS40 GD MASCHINENGEWICHT 1,5 - 2,0

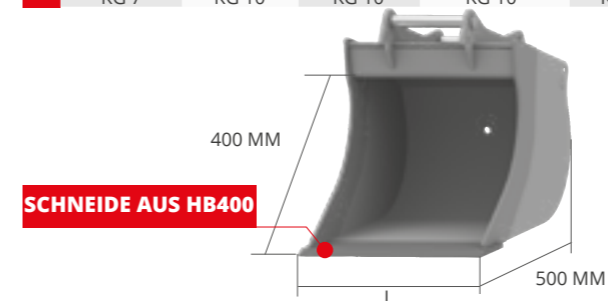

L MM	GEWICHT KG*	KAP. SAE L	ZÄHNE N°	ADAPTERS
300	23	35	3	AF - AR - CS
				CR - S - CM
				CW - CS JANUS PRO
400	30	45	3	AF - AR - CS
				CR - S - CM
				CW - CS JANUS PRO
500	38	60	4	AF - AR - CS
				CR - S - CM
				CW - CS JANUS PRO
600	45	85	4	AF - AR - CS
				CR - S - CM
				CW - CS JANUS PRO

ZUBEHÖR

5
UNTERSCHWEISS-
MESSER AUS HB500

SCS48 GD MASCHINENGEWICHT 2,0 - 3,0

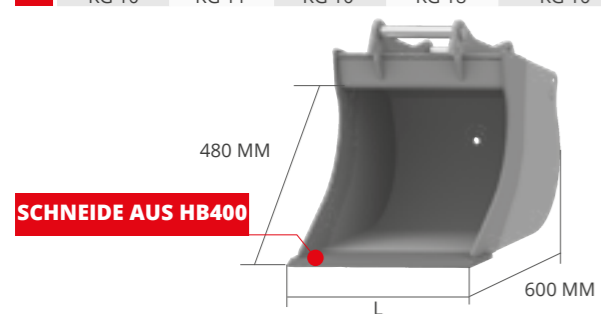

L MM	GEWICHT KG*	KAP. SAE L	ZÄHNE N°	ADAPTERS
300	34	48	3	AF - AR - CS
				CR - S - CM
				CW - CS JANUS PRO
400	43	68	3	AF - AR - CS
				CR - S - CM
				CW - CS JANUS PRO
500	55	85	4	AF - AR - CS
				CR - S - CM
				CW - CS JANUS PRO
600	65	110	4	AF - AR - CS
				CR - S - CM
				CW - CS JANUS PRO
800	90	160	5	AF - AR - CS
				CR - S - CM
				CW - CS JANUS PRO

ZUBEHÖR

5
UNTERSCHWEISS-
MESSER AUS HB500

SCS60 GD MASCHINENGEWICHT 3,0 - 4,0

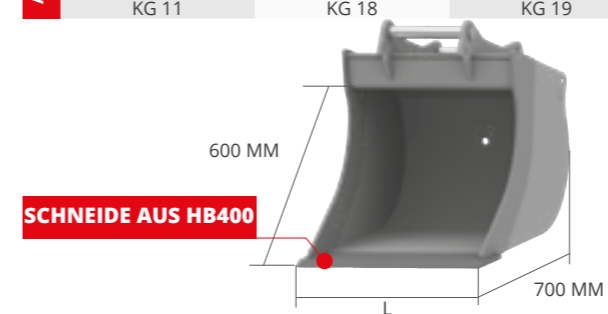

L MM	GEWICHT KG*	KAP. SAE L	ZÄHNE N°	ADAPTERS
300	44	78	3	AF - AR - CS
				CR - S - CM
				CW - CS JANUS PRO
400	54	105	3	AF - AR - CS
				CR - S - CM
				CW - CS JANUS PRO
500	66	140	4	AF - AR - CS
				CR - S - CM
				CW - CS JANUS PRO
600	80	165	4	AF - AR - CS
				CR - S - CM
				CW - CS JANUS PRO
800	100	225	5	AF - AR - CS
				CR - S - CM
				CW - CS JANUS PRO

ZUBEHÖR

5
UNTERSCHWEISS-
MESSER AUS HB500

* Gewicht des Löffel ohne Anbauteile und Zähne

* Gewicht des Löffel ohne Anbauteile und Zähne

SCS67 GD MASCHINENGEWICHT 4,0 - 6,0

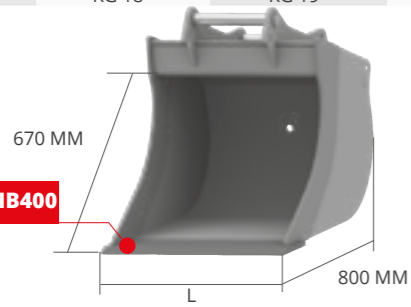

SCHNEIDE AUS HB400

ZUBEHÖR

5
UNTERSCHWEISS-
MESSER AUS HB500

L MM	GEWICHT KG*	KAP. SAE L	ZÄHNE N°	ADAPTERS
300	65	90	3	AF - AR - CS CR - S - CM CW - CS JANUS PRO
400	73	130	3	AF - AR - CS CR - S - CM CW - CS JANUS PRO
500	91	170	4	AF - AR - CS CR - S - CM CW - CS JANUS PRO
600	106	200	4	AF - AR - CS CR - S - CM CW - CS JANUS PRO
800	140	280	5	AF - AR - CS CR - S - CM CW - CS JANUS PRO

SCS71 GD MASCHINENGEWICHT 6,0 - 7,5

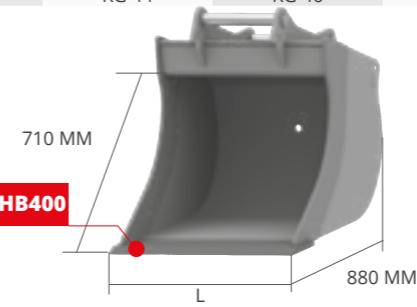
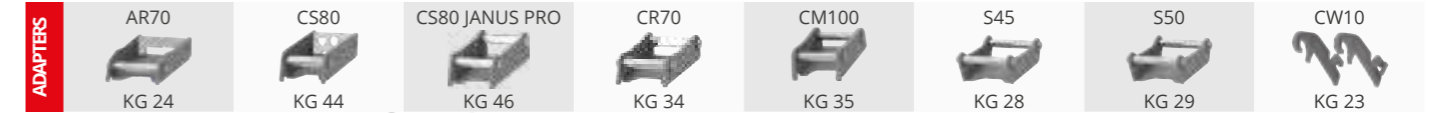

SCHNEIDE AUS HB400

ZUBEHÖR

5
UNTERSCHWEISS-
MESSER AUS HB500

L MM	GEWICHT KG*	KAP. SAE L	ZÄHNE N°	ADAPTERS
400	94	150	3	AF - AR - CS CR - S - CM CW - CS JANUS PRO
500	114	190	4	AF - AR - CS CR - S - CM CW - CS JANUS PRO
600	136	230	4	AF - AR - CS CR - S - CM CW - CS JANUS PRO
700	156	260	5	AF - AR - CS CR - S - CM CW - CS JANUS PRO
800	174	315	5	AF - AR - CS CR - S - CM CW - CS JANUS PRO

SCS75 GD MASCHINENGEWICHT 7,5 - 9,0

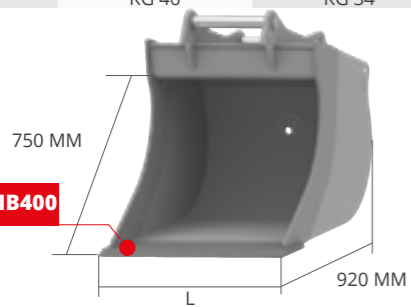

SCHNEIDE AUS HB400

ZUBEHÖR

5
UNTERSCHWEISS-
MESSER AUS HB500

L MM	GEWICHT KG*	KAP. SAE L	ZÄHNE N°	ADAPTERS
400	108	165	3	AF - CS CR - S - CM CW - CS JANUS PRO
500	128	210	4	AF - CS CR - S - CM CW - CS JANUS PRO
600	150	260	4	AF - CS CR - S - CM CW - CS JANUS PRO
700	175	300	5	AF - CS CR - S - CM CW - CS JANUS PRO
800	194	350	5	AF - CS CR - S - CM CW - CS JANUS PRO
1000	231	450	5	AF - CS CR - S - CM CW - CS JANUS PRO

* Gewicht des Löffel ohne Anbauteile und Zähne

SCS80 GD MASCHINENGEWICHT 9,0 - 12,0

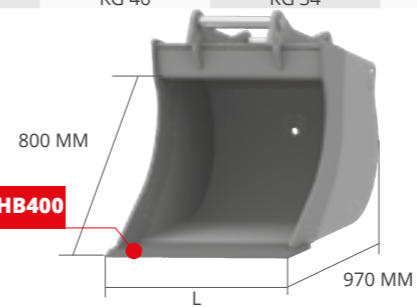
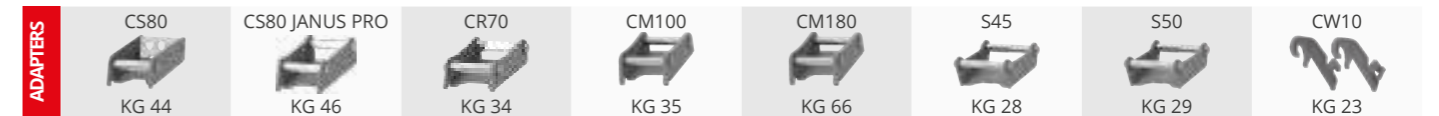

SCHNEIDE AUS HB400

ZUBEHÖR

5
UNTERSCHWEISS-
MESSER AUS HB500

L MM	GEWICHT KG*	KAP. SAE L	ZÄHNE N°	ADAPTERS
400	118	190	3	AF - CS CR - S - CM CW - CS JANUS PRO
500	135	245	3	AF - CS CR - S - CM CW - CS JANUS PRO
600	157	300	4	AF - CS CR - S - CM CW - CS JANUS PRO
700	185	350	4	AF - CS CR - S - CM CW - CS JANUS PRO
800	207	400	5	AF - CS CR - S - CM CW - CS JANUS PRO
1000	250	500	5	AF - CS CR - S - CM CW - CS JANUS PRO

* Gewicht des Löffel ohne Anbauteile und Zähne

SCS85 GD **MIDI** MASCHINENGEWICHT 12,0 - 14,0

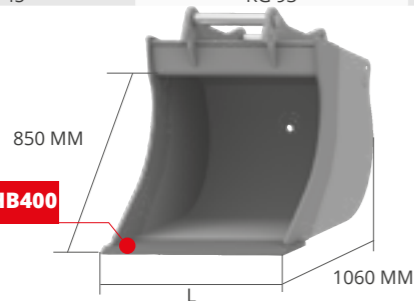

ZUBEHÖR

5
UNTERSCHWEISS-
MESSER AUS HB500

L MM	GEWICHT KG*	KAP. SAE L	ZÄHNE N°	ADAPTERS
500	175	265	3	AF - S - CM CS - CW CS JANUS PRO
600	200	330	4	AF - S - CM CS - CW CS JANUS PRO
700	228	400	4	AF - S - CM CS - CW CS JANUS PRO
800	253	450	5	AF - S - CM CS - CW CS JANUS PRO
900	278	500	5	AF - S - CM CS - CW CS JANUS PRO
1000	305	580	5	AF - S - CM CS - CW CS JANUS PRO
1200	340	740	6	AF - S - CM CS - CW CS JANUS PRO

SCS92 GD **EXCAVATOR** MASCHINENGEWICHT 12,0 - 14,0

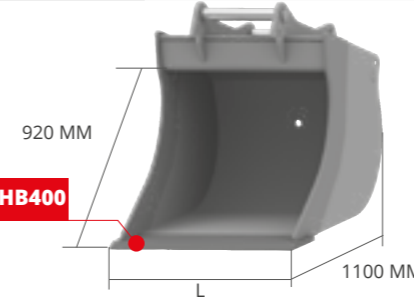

ZUBEHÖR

5
UNTERSCHWEISS-
MESSER AUS HB500

L MM	GEWICHT KG*	KAP. SAE L	ZÄHNE N°	ADAPTERS
600	228	380	4	AF - S - CM CS - CW CS JANUS PRO
700	251	450	4	AF - S - CM CS - CW CS JANUS PRO
800	281	560	4	AF - S - CM CS - CW CS JANUS PRO
900	309	620	5	AF - S - CM CS - CW CS JANUS PRO
1000	350	700	5	AF - S - CM CS - CW CS JANUS PRO
1200	403	900	6	AF - S - CM CS - CW CS JANUS PRO

SCS100 GD MASCHINENGEWICHT 14,0 - 18,0

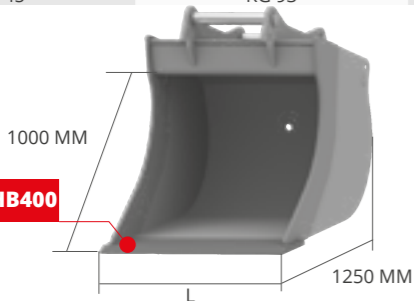

ZUBEHÖR

5
UNTERSCHWEISS-
MESSER AUS HB500

L MM	GEWICHT KG*	KAP. SAE L	ZÄHNE N°	ADAPTERS
600	316	450	3	AF - S - CM CS - CW CS JANUS PRO
700	355	535	4	AF - S - CM CS - CW CS JANUS PRO
800	394	620	4	AF - S - CM CS - CW CS JANUS PRO
900	433	710	4	AF - S - CM CS - CW CS JANUS PRO
1000	472	800	5	AF - S - CM CS - CW CS JANUS PRO
1200	550	980	5	AF - S - CM CS - CW CS JANUS PRO

SCS110 GD MASCHINENGEWICHT 18,0 - 22,0

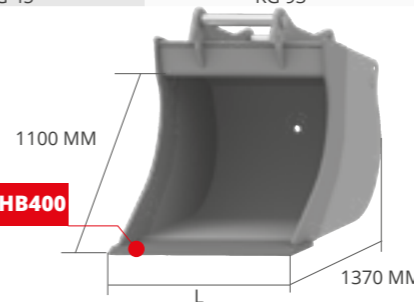

ZUBEHÖR

5
UNTERSCHWEISS-
MESSER AUS HB500

L MM	GEWICHT KG*	KAP. SAE L	ZÄHNE N°	ADAPTERS
600	412	480	3	AF - S - CM CS - CW CS JANUS PRO
800	502	690	4	AF - S - CM CS - CW CS JANUS PRO
1000	592	900	5	AF - S - CM CS - CW CS JANUS PRO
1200	682	1110	5	AF - S - CM CS - CW CS JANUS PRO
1300	727	1220	6	AF - S - CM CS - CW CS JANUS PRO
1400	772	1330	6	AF - S - CM CS - CW CS JANUS PRO

* Gewicht des Löffel ohne Anbauteile und Zähne

* Gewicht des Löffel ohne Anbauteile und Zähne