

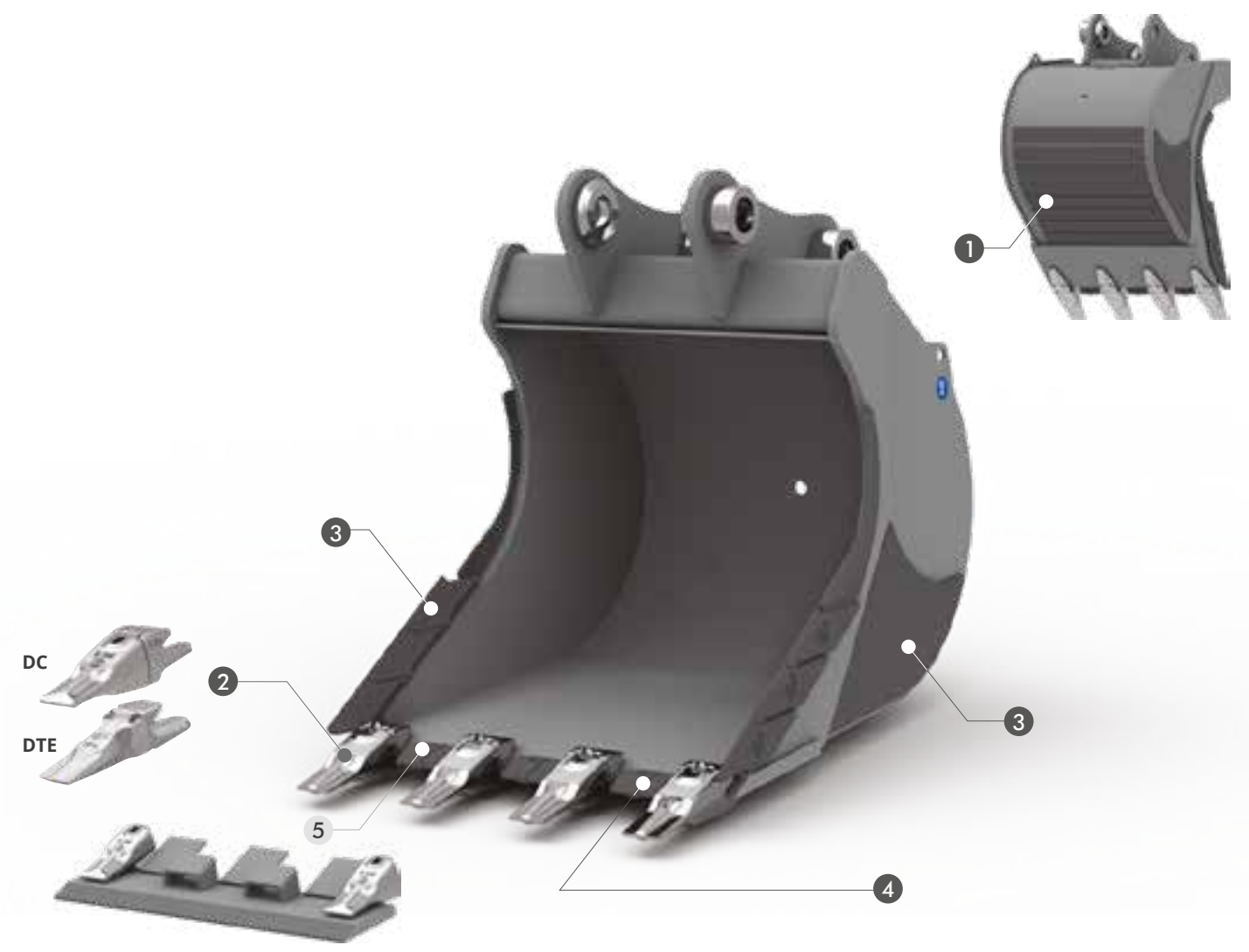

HB400



ITS PARTICULAR GEOMETRY ENABLES TO HANDLE STONE BLOCKS OR HEAVY MATERIALS EASILY. SPECIAL HB400 MATERIALS ARE USED TO STRENGTHEN PARTS SUBJECT TO WEAR AND ENSURE THEIR HIGH RESISTANCE.



STANDARD TECHNICAL FEATURES

- 1 REINFORCING STRIPS HB400**
THE HORIZONTAL REINFORCING STRIPS ON THE BUCKET'S REAR AND BOTTOM PROTECT THE BUCKET FROM WEAR AND INCREASE ITS RESISTANCE.
- 2 DC TEETH DTE TEETH**
- 3 HB400 SIDE CAST CUTTERS AND REINFORCEMENTS**
THESE HB400 CAST CUTTERS ARE POSITIONED ON THE SURFACES MOSTLY SUBJECT TO WEAR GRANTING A HIGHER RESISTANCE.
- 4 REINFORCED CUTTING EDGE**
UP TO 10 TONS: HB400 CAST SHROUDS MOUNTED ON PARTS SUBJECT TO WEAR.
BEYOND 10 TONS: HB400 CUTTING EDGE.

OPTIONAL

- 5 GRADING EDGE**
INSTALLED DIRECTLY ON THE ADAPTERS OF THE WELDED TEETH. THIS PATTERN MAKES THE INSTALLING/UNINSTALLING OPERATIONS EASIER AND GRANTS A HIGH RESISTANCE TO THE BUCKET.

MOD.	MIDI							EXCAVATOR			
	SB38	SB45	SB53	SB62	SB67	SB73	SB80	SB85	SB92 HD	SB100 HD	SB110 HD
TONS (LB)	1,2 - 1,8 (2646 - 3968)	1,8 - 2,5 (3968 - 5512)	2,5 - 4,0 (5512 - 8818)	4,0 - 5,0 (8818 - 11023)	5,0 - 7,5 (11023 - 16535)	7,5 - 10,0 (16535 - 22046)	10,0 - 12,0 (22046 - 26455)	12,0 - 14,0 (26455 - 30865)	12,0 - 14,0 (26455 - 30865)	14,0 - 18,0 (30865 - 39683)	18,0 - 22,0 (39683 - 48502)

SB38 MACHINE WEIGHT 1,2 - 1,8 t (2646 - 3968 lb)

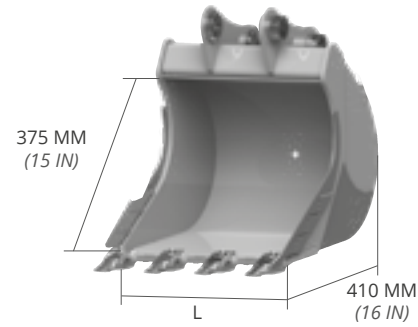
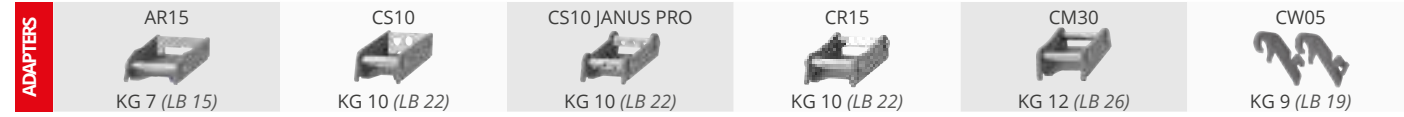

L MM (IN)	WEIGHT KG* (LB*)	CAP. SAE L (GAL)	TEETH N.	ADAPTERS
200 (8)	17 (38)	15 (4,0)	2	AF - AR - CS
				CR - CM
				CW - CS JANUS PRO
250 (10)	19 (43)	20 (5,3)	DF2 DC3 DE3	AF - AR - CS
				CR - CM
				CW - CS JANUS PRO
300 (12)	22 (48)	25 (6,6)	3	AF - AR - CS
				CR - CM
				CW - CS JANUS PRO
350 (14)	24 (52)	31 (8,2)	3	AF - AR - CS
				CR - CM
				CW - CS JANUS PRO
400 (16)	28 (61)	37 (9,8)	3	AF - AR - CS
				CR - CM
				CW - CS JANUS PRO
450 (18)	31 (68)	43 (11,4)	3	AF - AR - CS
				CR - CM
				CW - CS JANUS PRO
500 (20)	35 (76)	49 (12,4)	4	AF - AR - CS
				CR - CM
				CW - CS JANUS PRO
600 (24)	39 (86)	61 (16,1)	4	AF - AR - CS
				CR - CM
				CW - CS JANUS PRO
700 (28)	44 (98)	74 (19,5)	5	AF - AR - CS
				CR - CM
				CW - CS JANUS PRO

* weight of the tank excluding attachment

SB45 MACHINE WEIGHT 1,8 - 2,5 t (3968 - 5512 lb)

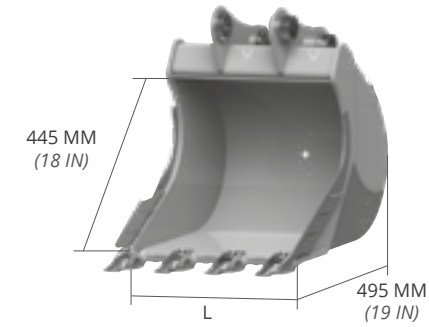

L MM (IN)	WEIGHT KG* (LB*)	CAP. SAE L (GAL)	TEETH N.	ADAPTERS
250 (10)	26 (57)	25 (6,6)	DF2 DC3 DE3	AF - AR - CS
				CR - CM
				CW - CS JANUS PRO
300 (12)	29 (64)	33 (8,7)	3	AF - AR - CS
				CR - CM
				CW - CS JANUS PRO
350 (14)	32 (71)	40 (10,6)	3	AF - AR - CS
				CR - CM
				CW - CS JANUS PRO
400 (16)	36 (80)	48 (12,7)	3	AF - AR - CS
				CR - CM
				CW - CS JANUS PRO
450 (18)	39 (87)	56 (14,8)	3	AF - AR - CS
				CR - CM
				CW - CS JANUS PRO
500 (20)	43 (95)	65 (17,2)	4	AF - AR - CS
				CR - CM
				CW - CS JANUS PRO
600 (24)	50 (109)	82 (21,7)	4	AF - AR - CS
				CR - CM
				CW - CS JANUS PRO
700 (28)	56 (123)	100 (26,4)	5	AF - AR - CS
				CR - CM
				CW - CS JANUS PRO
800 (31)	65 (142)	117 (30,9)	5	AF - AR - CS
				CR - CM
				CW - CS JANUS PRO

* weight of the tank excluding attachment

OPTIONAL

5
SUPPLEMENTARY
BLADE

OPTIONAL

5
SUPPLEMENTARY
BLADE

SB53 MACHINE WEIGHT 2,5 - 4,0 t (5512 - 8818 lb)

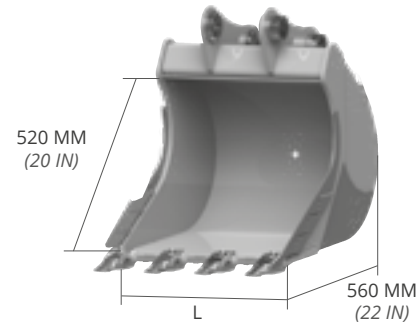
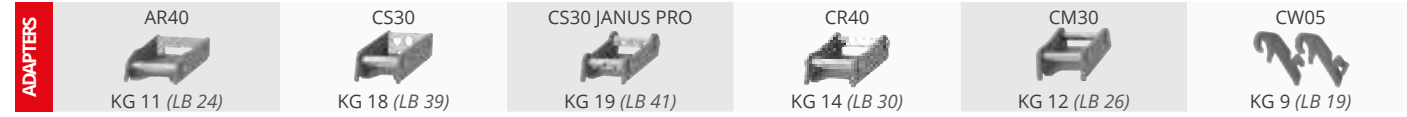

L MM (IN)	WEIGHT KG* (LB*)	CAP. SAE L (GAL)	TEETH N.	ADAPTERS
250 (10)	37 (82)	32 (8,5)	2	AF - AR - CS
				CR - CM
				CW - CS JANUS PRO
300 (12)	40 (89)	41 (10,8)	3	AF - AR - CS
				CR - CM
				CW - CS JANUS PRO
350 (14)	46 (101)	51 (13,5)	3	AF - AR - CS
				CR - CM
				CW - CS JANUS PRO
400 (16)	51 (111)	61 (16,1)	3	AF - AR - CS
				CR - CM
				CW - CS JANUS PRO
450 (18)	55 (121)	72 (19,0)	3	AF - AR - CS
				CR - CM
				CW - CS JANUS PRO
500 (20)	59 (129)	82 (21,7)	4	AF - AR - CS
				CR - CM
				CW - CS JANUS PRO
600 (24)	67 (148)	105 (27,7)	4	AF - AR - CS
				CR - CM
				CW - CS JANUS PRO
700 (28)	76 (167)	127 (33,5)	5	AF - AR - CS
				CR - CM
				CW - CS JANUS PRO
800 (31)	85 (187)	152 (40,2)	5	AF - AR - CS
				CR - CM
				CW - CS JANUS PRO
900 (35)	93 (206)	175 (46,2)	5	AF - AR - CS
				CR - CM
				CW - CS JANUS PRO

* weight of the tank excluding attachment

SB62 MACHINE WEIGHT 4,0 - 5,0 t (8818 - 11023 lb)

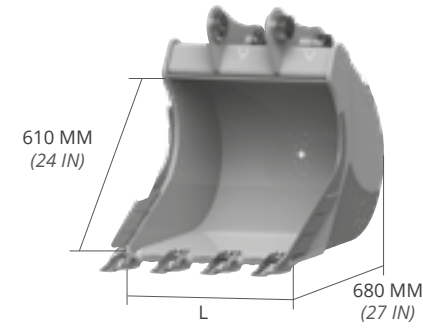
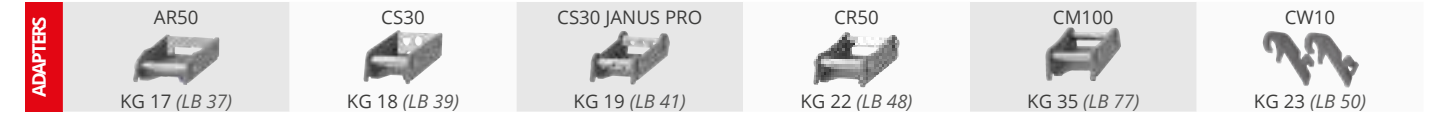

L MM (IN)	WEIGHT KG* (LB*)	CAP. SAE L (GAL)	TEETH N.	ADAPTERS
250 (10)	57 (126)	45 (11,9)	2	AF - AR - CS
				CR - CM
				CW - CS JANUS PRO
300 (12)	63 (138)	58 (15,3)	3	AF - AR - CS
				CR - CM
				CW - CS JANUS PRO
350 (14)	68 (150)	71 (18,8)	3	AF - AR - CS
				CR - CM
				CW - CS JANUS PRO
400 (16)	74 (163)	85 (22,5)	3	AF - AR - CS
				CR - CM
				CW - CS JANUS PRO
450 (18)	79 (175)	100 (26,4)	3	AF - AR - CS
				CR - CM
				CW - CS JANUS PRO
500 (20)	86 (188)	115 (30,4)	4	AF - AR - CS
				CR - CM
				CW - CS JANUS PRO
600 (24)	97 (215)	147 (38,8)	4	AF - AR - CS
				CR - CM
				CW - CS JANUS PRO
700 (28)	109 (241)	180 (47,6)	5	AF - AR - CS
				CR - CM
				CW - CS JANUS PRO
800 (31)	121 (267)	213 (56,3)	5	AF - AR - CS
				CR - CM
				CW - CS JANUS PRO
900 (35)	133 (293)	248 (65,5)	6	AF - AR - CS
				CR - CM
				CW - CS JANUS PRO
1000 (39)	145 (319)	282 (74,5)	6	AF - AR - CS
				CR - CM
				CW - CS JANUS PRO

* weight of the tank excluding attachment

OPTIONAL

5
SUPPLEMENTARY
BLADE

OPTIONAL

5
SUPPLEMENTARY
BLADE

SB67 MACHINE WEIGHT 5,0 - 7,5 t (11023 - 16535 lb)

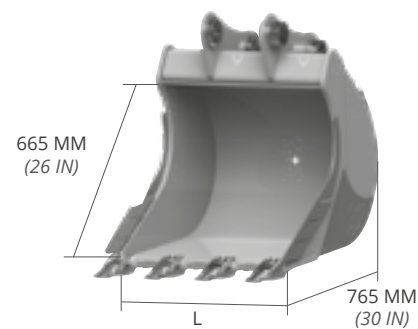
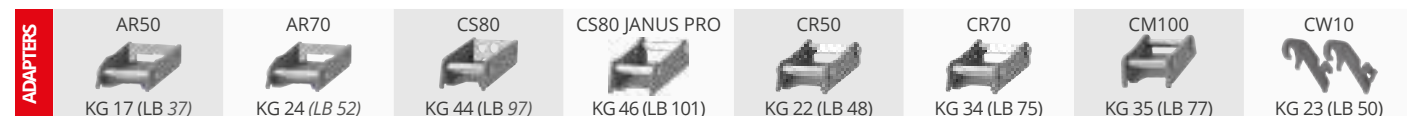

L MM (IN)	WEIGHT KG* (LB*)	CAP. SAE L (GAL)	TEETH N.	ADAPTERS
300 (12)	83 (182)	68 (18,0)	3	AF - AR - CS
				CR - CM
				CW - CS JANUS PRO
350 (14)	92 (202)	84 (22,2)	3	AF - AR - CS
				CR - CM
				CW - CS JANUS PRO
400 (16)	101 (222)	101 (26,7)	3	AF - AR - CS
				CR - CM
				CW - CS JANUS PRO
450 (18)	109 (240)	118 (31,2)	3	AF - AR - CS
				CR - CM
				CW - CS JANUS PRO
500 (20)	117 (258)	137 (36,2)	4	AF - AR - CS
				CR - CM
				CW - CS JANUS PRO
600 (24)	134 (296)	174 (46,0)	4	AF - AR - CS
				CR - CM
				CW - CS JANUS PRO
700 (28)	150 (331)	214 (56,5)	5	AF - AR - CS
				CR - CM
				CW - CS JANUS PRO
800 (31)	167 (368)	254 (67,1)	5	AF - AR - CS
				CR - CM
				CW - CS JANUS PRO
900 (35)	183 (403)	295 (77,9)	6	AF - AR - CS
				CR - CM
				CW - CS JANUS PRO
1000 (39)	199 (438)	338 (89,3)	6	AF - AR - CS
				CR - CM
				CW - CS JANUS PRO

* weight of the tank excluding attachment

SB73 MACHINE WEIGHT 7,5 - 10,0 t (116535 - 22046 lb)

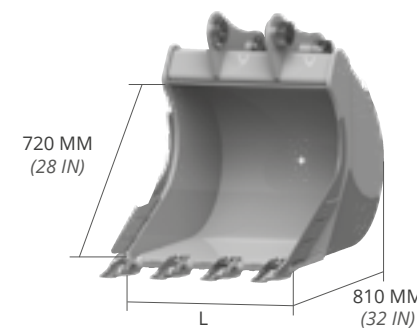

L MM (IN)	WEIGHT KG* (LB*)	CAP. SAE L (GAL)	TEETH N.	ADAPTERS
300 (12)	95 (210)	76 (20,1)	2	AF - CS
				CR - CM
				CW - CS JANUS PRO
350 (14)	103 (228)	94 (24,8)	3	AF - CS
				CR - CM
				CW - CS JANUS PRO
400 (16)	110 (243)	113 (29,9)	3	AF - CS
				CR - CM
				CW - CS JANUS PRO
450 (18)	120 (265)	133 (35,1)	3	AF - CS
				CR - CM
				CW - CS JANUS PRO
500 (20)	130 (286)	153 (40,4)	3	AF - CS
				CR - CM
				CW - CS JANUS PRO
600 (24)	148 (326)	196 (51,8)	4	AF - CS
				CR - CM
				CW - CS JANUS PRO
700 (28)	166 (366)	240 (63,4)	4	AF - CS
				CR - CM
				CW - CS JANUS PRO
800 (31)	184 (406)	286 (75,6)	5	AF - CS
				CR - CM
				CW - CS JANUS PRO
900 (35)	202 (446)	333 (88,0)	5	AF - CS
				CR - CM
				CW - CS JANUS PRO
1000 (39)	220 (486)	379 (100,1)	5	AF - CS
				CR - CM
				CW - CS JANUS PRO
1100 (43)	238 (525)	430 (113,6)	5	AF - CS
				CR - CM
				CW - CS JANUS PRO

* weight of the tank excluding attachment

OPTIONAL

5
SUPPLEMENTARY
BLADE

OPTIONAL

5
SUPPLEMENTARY
BLADE

SB80 SC80 MACHINE WEIGHT 10,0 - 12,0 t (22046 - 26455 lb)

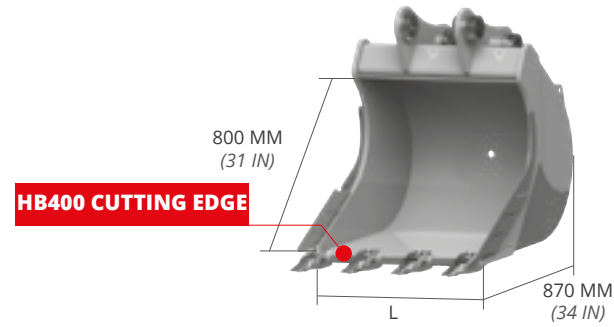

L MM (IN)	WEIGHT KG* (LB*)	CAP. SAE L (GAL)	TEETH N.	ADAPTERS
300 (12)	119 (261)	86 (22,7)	2	AF - CS
				CR - CM - CS JANUS PRO
				CW
350 (14)	128 (282)	107 (28,3)	3	AF - CS
				CR - CM - CS JANUS PRO
				CW
400 (16)	141 (311)	129 (34,1)	3	AF - CS
				CR - CM - CS JANUS PRO
				CW
450 (18)	151 (333)	151 (39,9)	3	AF - CS
				CR - CM - CS JANUS PRO
				CW
500 (20)	162 (357)	174 (46,0)	3	AF - CS
				CR - CM - CS JANUS PRO
				CW
600 (24)	182 (402)	222 (58,6)	4	AF - CS
				CR - CM - CS JANUS PRO
				CW
700 (28)	203 (447)	273 (72,1)	4	AF - CS
				CR - CM - CS JANUS PRO
				CW
800 (31)	222 (489)	325 (85,9)	5	AF - CS
				CR - CM - CS JANUS PRO
				CW
900 (35)	242 (534)	379 (100,1)	5	AF - CS
				CR - CM - CS JANUS PRO
				CW
1000 (39)	261 (576)	433 (114,4)	5	AF - CS
				CR - CM - CS JANUS PRO
				CW
1100 (43)	282 (621)	486 (128,4)	5	AF - CS
				CR - CM - CS JANUS PRO
				CW
1200 (47)	303 (667)	546 (144,2)	6	AF - CS
				CR - CM - CS JANUS PRO
				CW
1300 (51)	323 (712)	602 (159,0)	6	AF - CS
				CR - CM - CS JANUS PRO
				CW

* weight of the tank excluding attachment

SB85 MIDI MACHINE WEIGHT 12,0 - 14,0 t (26455 - 30865 lb)

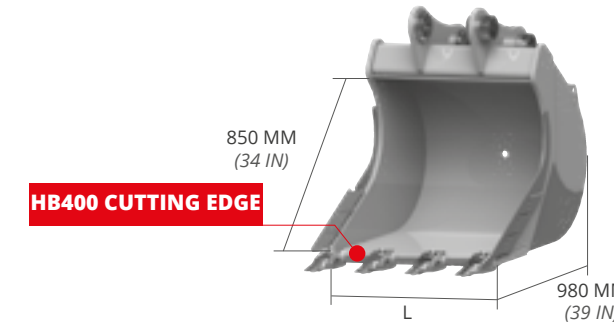

L MM (IN)	VWEIGHT KG* (LB*)	CAP. SAE L (GAL)	TEETH N.	ADAPTERS
400 (16)	197 (435)	171 (45,2)	3	AF - CM
				CS - CW
				CS JANUS PRO
500 (20)	220 (486)	235 (62,1)	3	AF - CM
				CS - CW
				CS JANUS PRO
600 (24)	243 (536)	300 (79,3)	4	AF - CM
				CS - CW
				CS JANUS PRO
700 (28)	266 (586)	368 (97,2)	4	AF - CM
				CS - CW
				CS JANUS PRO
800 (31)	289 (638)	438 (115,7)	5	AF - CM
				CS - CW
				CS JANUS PRO
900 (35)	312 (688)	510 (134,7)	5	AF - CM
				CS - CW
				CS JANUS PRO
1000 (39)	336 (741)	584 (154,3)	5	AF - CM
				CS - CW
				CS JANUS PRO
1100 (43)	360 (793)	657 (173,6)	5	AF - CM
				CS - CW
				CS JANUS PRO
1200 (47)	384 (847)	730 (192,8)	6	AF - CM
				CS - CW
				CS JANUS PRO
1300 (51)	408 (899)	810 (214,0)	6	AF - CM
				CS - CW
				CS JANUS PRO

* weight of the tank excluding attachment

OPTIONAL

5 SUPPLEMENTARY BLADE

OPTIONAL

5 SUPPLEMENTARY BLADE

SB92 HD EXCAVATOR MACHINE WEIGHT 12,0 - 14,0 t (26455 - 30865 lb)

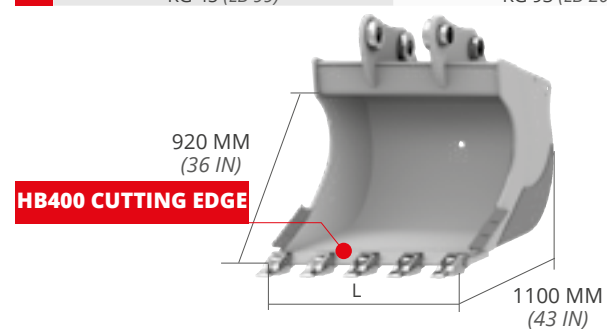
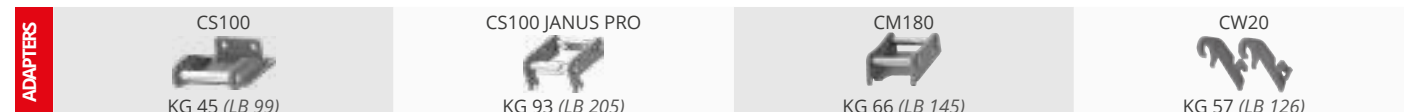

OPTIONAL

L MM (IN)	WEIGHT KG* (LB*)	CAP. SAE L (GAL)	TEETH N.	ADAPTERS
600 (24)	259 (571)	337 (89,0)	4	AF - CM
				CS - CW
				CS JANUS PRO
700 (28)	280 (617)	405 (107,0)	4	AF - CM
				CS - CW
				CS JANUS PRO
800 (31)	315 (694)	475 (125,5)	5	AF - CM
				CS - CW
				CS JANUS PRO
900 (35)	350 (772)	547 (144,5)	5	AF - CM
				CS - CW
				CS JANUS PRO
1000 (39)	385 (849)	622 (164,3)	5	AF - CM
				CS - CW
				CS JANUS PRO
1200 (47)	421 (928)	783 (206,8)	6	AF - CM
				CS - CW
				CS JANUS PRO

5	ADAPTERS
SUPPLEMENTARY BLADE	

SB100 HD MACHINE WEIGHT 14,0 - 18,0 t (30865 - 39683 lb)

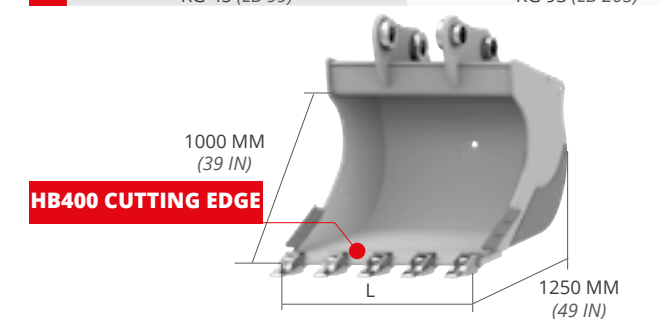
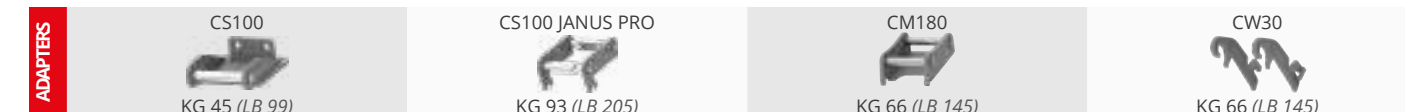

OPTIONAL

L MM (IN)	WEIGHT KG* (LB*)	CAP. SAE L (GAL)	TEETH N.	ADAPTERS
600 (24)	346 (763)	398 (105,1)	3	AF - CM
				CS - CW
				CS JANUS PRO
700 (28)	386 (851)	478 (126,3)	4	AF - CM
				CS - CW
				CS JANUS PRO
800 (31)	426 (939)	560 (147,9)	4	AF - CM
				CS - CW
				CS JANUS PRO
900 (35)	466 (1027)	644 (170,1)	4	AF - CM
				CS - CW
				CS JANUS PRO
1000 (39)	506 (1116)	730 (192,8)	5	AF - CM
				CS - CW
				CS JANUS PRO
1200 (47)	586 (1292)	909 (240,1)	5	AF - CM
				CS - CW
				CS JANUS PRO

5	ADAPTERS
SUPPLEMENTARY BLADE	

SB110 HD MACHINE WEIGHT 18,0 - 22,0 t (39683 - 48502 lb)

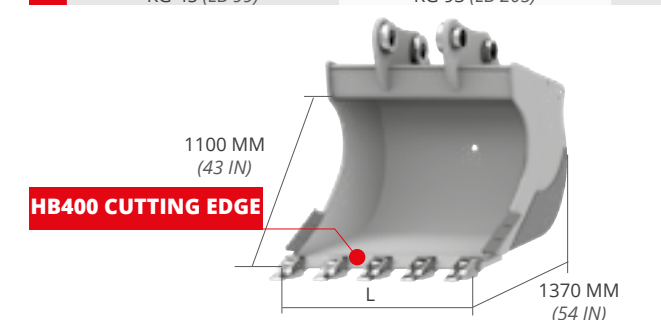

OPTIONAL

L MM (IN)	WEIGHT KG* (LB*)	CAP. SAE L (GAL)	TEETH N.	ADAPTERS
600 (24)	437 (963)	464 (122,6)	3	AF - CM
				CS - CW
				CS JANUS PRO
800 (31)	539 (1188)	654 (172,8)	4	AF - CM
				CS - CW
				CS JANUS PRO
1000 (39)	641 (1413)	854 (225,6)	5	AF - CM
				CS - CW
				CS JANUS PRO
1200 (47)	743 (1638)	1064 (281,1)	5	AF - CM
				CS - CW
				CS JANUS PRO
1300 (52)	794 (1750)	1173 (309,9)	6	AF - CM
				CS - CW
				CS JANUS PRO
1400 (55)	845 (1863)	1288 (340,3)	6	AF - CM
				CS - CW
				CS JANUS PRO

5	ADAPTERS
SUPPLEMENTARY BLADE	

* weight of the tank excluding attachment

* weight of the tank excluding attachment