



NB: AT THE TIME OF ORDER, PLEASE NOTIFY THE VOLTAGE OF THE ELECTRICAL SYSTEM (12-24 V)

THE CS SCHNAPPMATIC PATENTED QUICK COUPLER ENABLES THE FAST LOCKING AND UNLOCKING OF THE ATTACHMENTS, CONSIDERABLY REDUCING THE TIME FOR THEIR REPLACEMENT. THE MECHANICAL VERSION IS PROVIDED WITH A SEMI-AUTOMATIC SYSTEM THAT REQUIRES THE MANUAL INTERVENTION WHEN THE TOOL HAS TO BE RELEASED. BOTH THE LOCKING AND THE SAFE BLOCKING OF THE NEW TOOL ARE AUTOMATIC OPERATIONS. IN THE HYDRAULIC VERSION ALL THESE FUNCTIONS ARE MANAGED FROM THE CAB. ACCORDING TO THE ADAPTER, STANDARD OR JANUS PRO (REVERSIBLE), IT IS POSSIBLE TO USE THE SAME TOOLS ALSO FOR FRONT DIGGING WORKS. THIS QUICK COUPLER COMBINES WITH ALL TYPES OF ADAPTER OF THE (MS OS, DS, ETC.) 01, 03 AND 08 SERIES.



	TONS (LB)	0,6 - 2,5 (1323 - 5512)	2,5 - 6,0 (5512 - 13227)	5,0 - 12,0 (11023 - 26455)
MOD.		CS10	CS30	CS80
A MM (IN)		250 (9,8)	316 (12,5)	436 (17,2)
B MM (IN)		180 (7,1)	200 (8)	290 (11)
C MM (IN)		72 (2,8)	78 (3,1)	105 (4,1)
Ø MM (IN)		40 (1,6)	50 (2,0)	60 (2,4)

MECHANIC SEMI-AUTOMATIC		MOD.	CS10 S.A.	CS30 S.A.	CS80 S.A.
	W/O COUPLER	KG (LB)	22 (49)	33 (73)	83 (183)

HYDRAULIC SINGLE ACTION		MOD.	CS10 S.E.	CS30 S.E.	CS80 S.E.
	W/O COUPLER	KG (LB)	23 (51)	34 (75)	87 (192)
	MAX	BAR (PSI)	250 (3626)	250 (3626)	250 (3626)

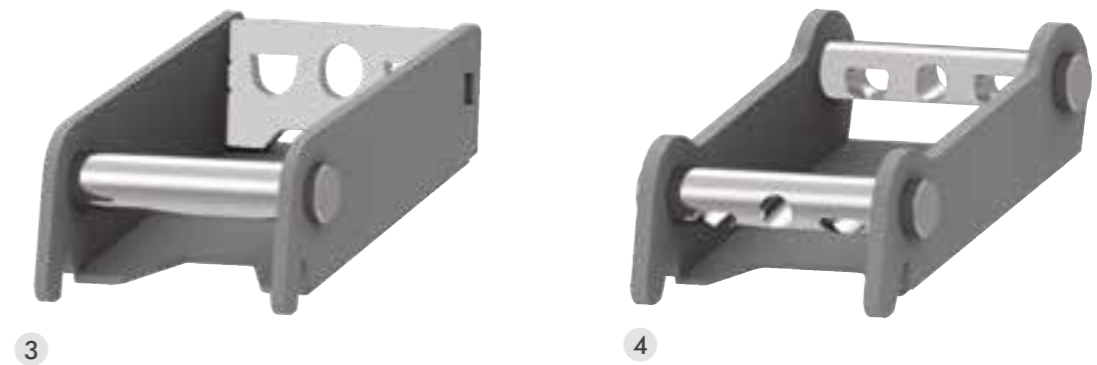

OPTIONAL

1 HYDRAULIC INSTALLATION KIT

WITH THE HYDRAULIC QUICK COUPLER THE INSTALLATION KIT CAN BE PROVIDED, INCLUDING SOLENOID VALVE AND ELECTRIC SWITCH WITH MAGNETS TO EASILY PUT IT INSIDE THE CAB

2 LIFTING HOOK

A HOOK APPROVED FOR LIFTING OPERATIONS CAN BE WELDED DIRECTLY ON THE QUICK COUPLER.

3 CS ADAPTER

THE ADAPTER APPLIED TO ANY TOOL ENABLES THE COUPLING WITH THE CS SCHNAPPMATIC QUICK COUPLER.

4 JANUS PRO ADAPTER

THE JANUS PRO ADAPTER MAKES THE TOOL REVERSIBLE.