

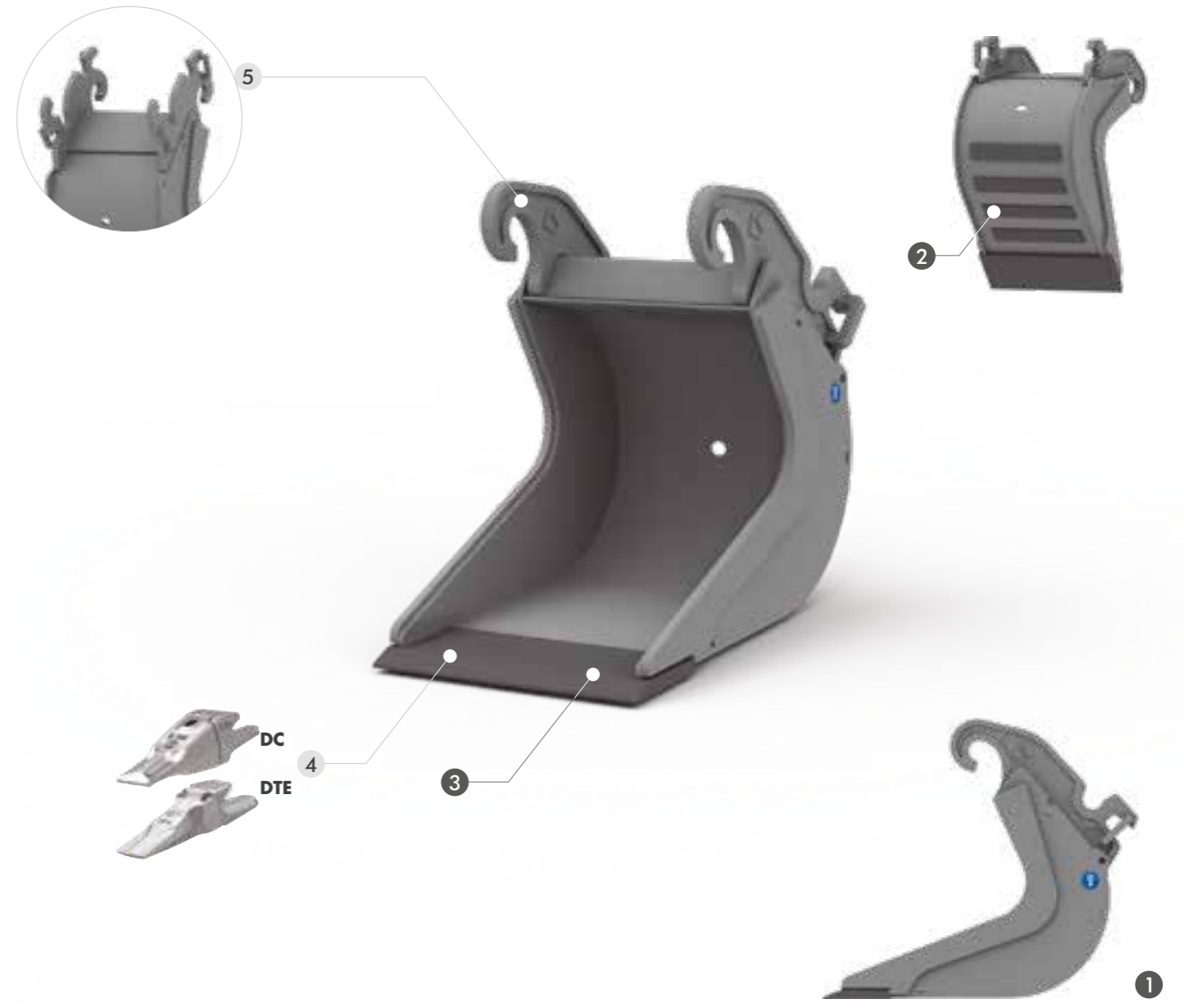

HB400



CHARACTERISTIQUES TECHNIQUES STANDARD

- 1 PROFIL ALLONGÉ**
- 2 BANDES DE RENFORCEMENT**
LES BANDES DE RENFORCEMENT HORIZONTALES PROTÈGENT LE FOND EN AUGMENTANT SA RÉSISTANCE À L'USURE.
- 3 LAME EN HB400**

EN OPTION

- 4 DENTS DC OU DENTS DTE**
- 5 VERSION RÉVERSIBLE CW**
CET ADAPTEUR PERMET DE RENDRE LE GODET RÉVERSIBLE.

SA FORME ALLONGÉE EMPÊCHE QUE LE TERRAIN ADHÈRE AUX PAROIS LATÉRALES DU GODET ET FACILITE LE DECHARGEMENT DES MATÉRIAUX ARGILEUX ET MOUILLÉS. SES FLANCS ÉCHANCRÉS FACILITENT LES OPÉRATIONS EN PROXIMITÉ DES CONDUITES HYDRAULIQUES, DU GAZ, ETC. CE GODET EST DOTÉ DE LAME EN HB400.

MOD.	BN35	BN41	BN52	BN60	BN66	BN75	BN90
TONS	0,6 - 1,2	1,2 - 1,8	1,8 - 2,5	2,5 - 4,0	4,0 - 6,0	6,0 - 7,5	7,5 - 12,0

BN35 POIDS MACHINE 0,6 - 1,2

ADAPTERS

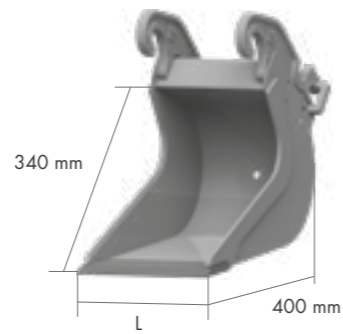

EN OPTION

4 4 5
Dents DC Dents DTE Version réversible CW

L mm	POIDS Kg*	CAP. SAE l	
220	17	16	AF
220	17	16	CW
250	18	18	AF
250	18	18	CW
300	20	22	AF
300	20	22	CW

BN41 POIDS MACHINE 1,2 - 1,8

ADAPTERS

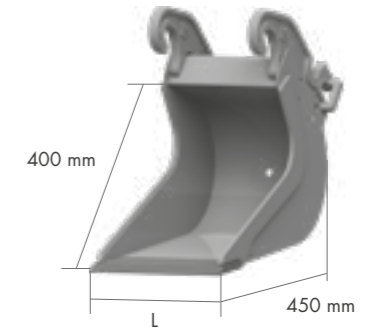

L mm	POIDS Kg*	CAP. SAE l	
220	19	20	AF
220	19	20	CW
250	20	23	AF
250	20	23	CW
300	22	28	AF
300	22	28	CW
350	24	34	AF
350	24	34	CW

EN OPTION

4 4 5
Dents DC Dents DTE Version réversible CW

BN52 POIDS MACHINE 1,8 - 2,5

ADAPTERS

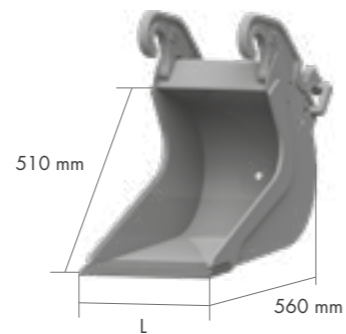

EN OPTION

4 4 5
Dents DC Dents DTE Version réversible CW

L mm	POIDS Kg*	CAP. SAE l	
220	25	27	AF
220	25	27	CW
250	27	32	AF
250	27	32	CW
300	29	38	AF
300	29	38	CW
350	33	46	AF
350	33	46	CW

BN60 POIDS MACHINE 2,5 - 4,0

ADAPTERS

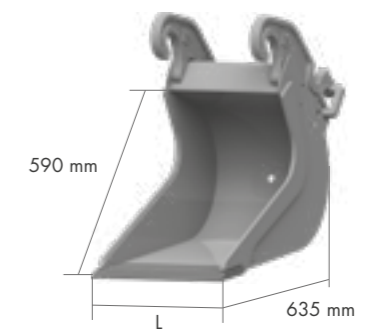

EN OPTION

4 4 5
Dents DC Dents DTE Version réversible CW

L mm	POIDS Kg*	CAP. SAE l	
220	31	38	AF
220	31	38	CW
250	33	45	AF
250	33	45	CW
300	36	53	AF
300	36	53	CW
350	40	65	AF
350	40	65	CW
400	44	77	AF
400	44	77	CW

* poids cuve sans attache

* poids cuve sans attache

BN66 POIDS MACHINE 4,0 - 6,0

ADAPTERS

CW10
KG 23

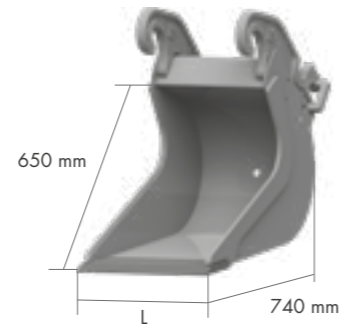

EN OPTION

4 4 5
Dents DC Dents DTE Version réversible CW

L mm	POIDS Kg*	CAP. SAE l	
220	39	42	AF
220	39	42	CW
250	42	50	AF
250	42	50	CW
300	48	77	AF
300	48	77	CW
350	51	83	AF
350	51	83	CW
400	56	92	AF
400	56	92	CW

BN75 POIDS MACHINE 6,0 - 7,5

ADAPTERS

CW10
KG 23

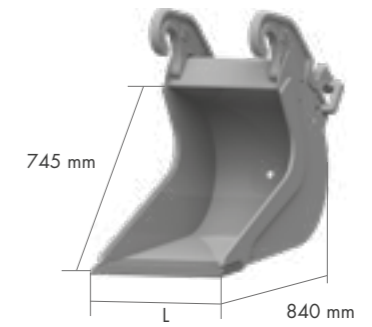

L mm	POIDS Kg*	CAP. SAE l	
250	67	59	AF
250	67	59	CW
300	71	74	AF
300	71	74	CW
350	73	91	AF
350	73	91	CW
400	74	106	AF
400	74	106	CW

EN OPTION

4 4 5
Dents DC Dents DTE Version réversible CW

BN90 POIDS MACHINE 7,5 - 12,0

ADAPTERS

CW10
KG 23

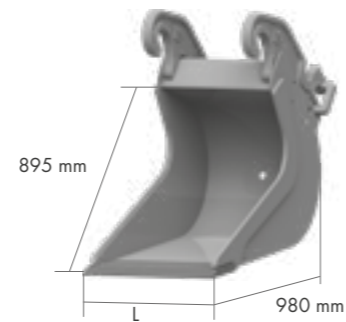

EN OPTION

4 4 5
Dents DC Dents DTE Version réversible CW

L mm	POIDS Kg*	CAP. SAE l	
300	90	78	AF
300	90	78	CW
350	96	100	AF
350	96	100	CW
400	100	123	AF
400	100	123	CW
450	106	146	AF
450	106	146	CW
500	115	171	AF
500	115	171	CW

* poids cuve sans attache

* poids cuve sans attache