

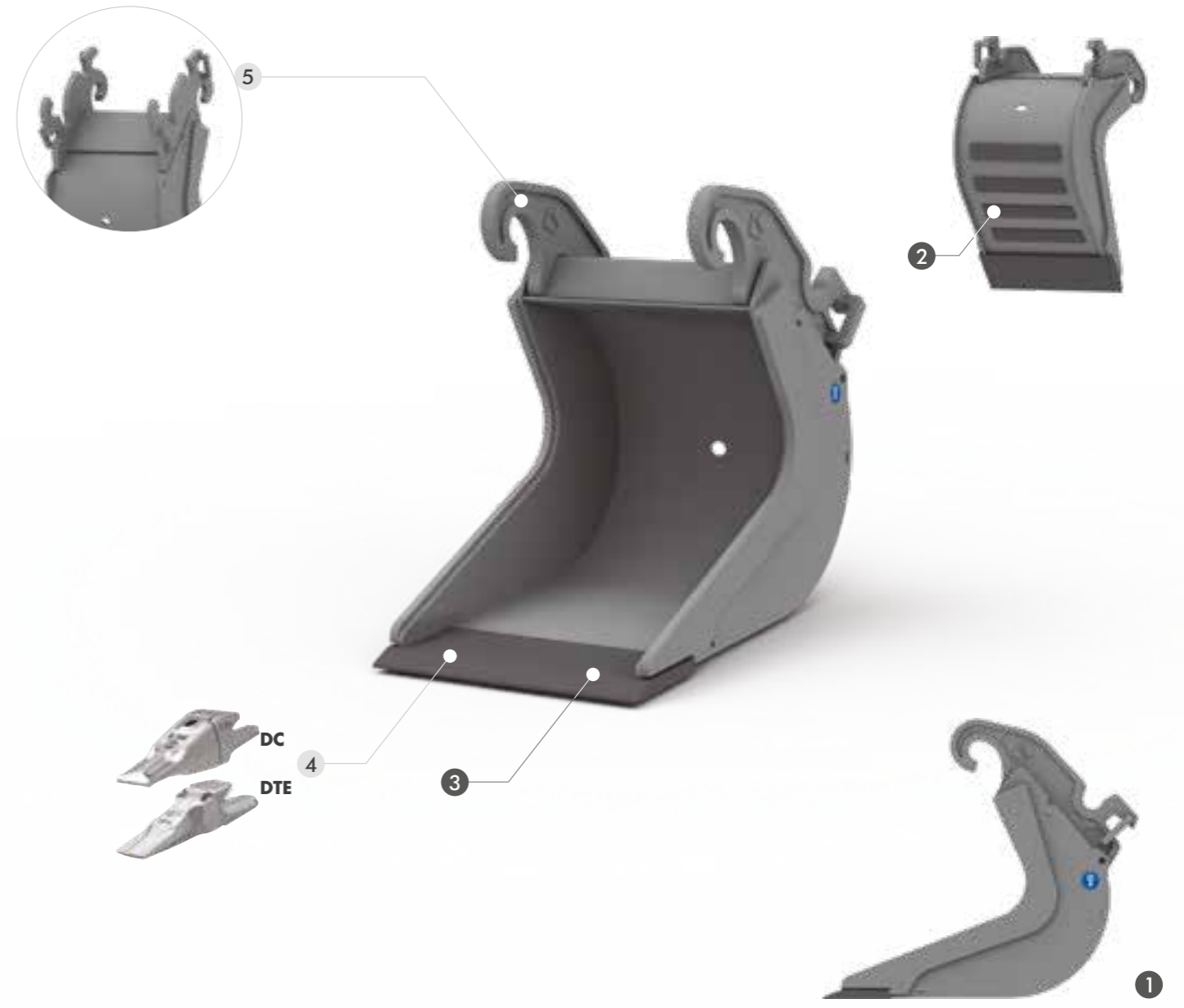

ADAPTERS



HB400



STANDARD TECHNICAL FEATURES

- 1 ELONGATED PROFILE**
- 2 REINFORCING STRIPS**
THE HORIZONTAL REINFORCING STRIPS ON THE BUCKET'S REAR AND BOTTOM PROTECT THE BUCKET FROM WEAR AND INCREASE ITS RESISTANCE.
- 3 HB400 BLADE**

OPTIONAL

- 4 DC TEETH OR DTE TEETH**
- 5 CW REVERSIBLE VERSION**
THIS ADAPTER MAKES THE BUCKET REVERSIBLE.

ITS ELONGATED SHAPE AVOIDS THAT THE GROUND STICKS TO THE BUCKET'S SIDE WALLS AND SIMPLIFIES THE DISCHARGE OF LOAMY AND WET MATERIALS. ITS HOLLOW SIDE WALLS HELP THE CROSSING OF GAS AND HYDRAULIC PIPES OR PLANTS, ETC. IT IS EQUIPPED WITH HB400 BLADE.

MOD.	BN35	BN41	BN52	BN60	BN66	BN75	BN90
Tons (lb)	0,6 - 1,2 (1323 - 2646)	1,2 - 1,8 (2646 - 3968)	1,8 - 2,5 (3968 - 5512)	2,5 - 4,0 (5512 - 8818)	4,0 - 6,0 (8818 - 13228)	6,0 - 7,5 (13228 - 16535)	7,5 - 12,0 (16535 - 26455)

BN35 MACHINE WEIGHT 0,6 - 1,2 t (1323 - 2646 lb)

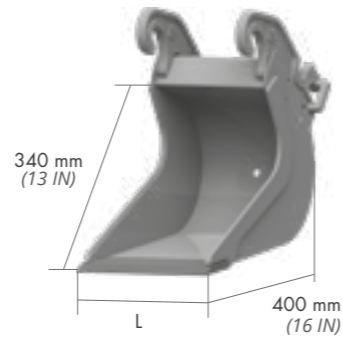

L mm (in)	WEIGHT Kg* (lb*)	CAP. SAE l (gal)	
220 (9)	17 (37)	16 (4,2)	AF
220 (9)	17 (37)	16 (4,2)	CW
250 (10)	18 (40)	18 (4,8)	AF
250 (10)	18 (40)	18 (4,8)	CW
300 (12)	20 (44)	22 (5,8)	AF
300 (12)	20 (44)	22 (5,8)	CW

OPTIONAL

4	4	5
DC teeth	DTE teeth	CW reversible version

BN41 MACHINE WEIGHT 1,2 - 1,8 t (2646 - 3968 lb)

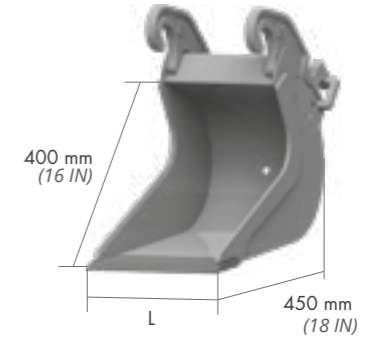

L mm (in)	WEIGHT Kg* (lb*)	CAP. SAE l (gal)	
220 (9)	19 (42)	20 (5,3)	AF
220 (9)	19 (42)	20 (5,3)	CW
250 (10)	20 (44)	23 (6,1)	AF
250 (10)	20 (44)	23 (6,1)	CW
300 (12)	22 (49)	28 (7,4)	AF
300 (12)	22 (49)	28 (7,4)	CW
350 (14)	24 (53)	34 (9,0)	AF
350 (14)	24 (53)	34 (9,0)	CW

OPTIONAL

4	4	5
DC teeth	DTE teeth	CW reversible version

BN52 MACHINE WEIGHT 1,8 - 2,5 t (3968 - 5512 lb)

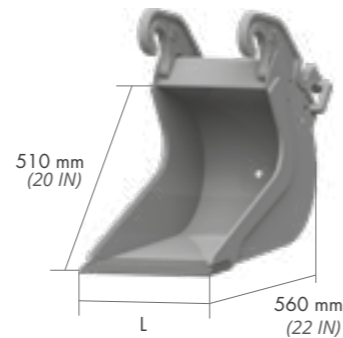
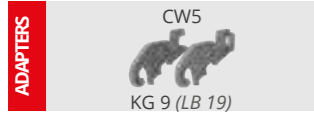

L mm (in)	WEIGHT Kg* (lb*)	CAP. SAE l (gal)	
220 (9)	25 (55)	27 (7,1)	AF
220 (9)	25 (55)	27 (7,1)	CW
250 (10)	27 (60)	32 (8,5)	AF
250 (10)	27 (60)	32 (8,5)	CW
300 (12)	29 (64)	38 (10,0)	AF
300 (12)	29 (64)	38 (10,0)	CW
350 (14)	33 (73)	46 (12,2)	AF
350 (14)	33 (73)	46 (12,2)	CW

OPTIONAL

4	4	5
DC teeth	DTE teeth	CW reversible version

BN60 MACHINE WEIGHT 2,5 - 4,0 t (5512 - 8818 lb)

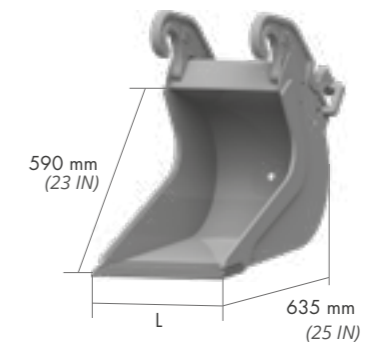

L mm (in)	WEIGHT Kg* (lb*)	CAP. SAE l (gal)	
220 (9)	31 (68)	38 (10,0)	AF
220 (9)	31 (68)	38 (10,0)	CW
250 (10)	33 (73)	45 (11,9)	AF
250 (10)	33 (73)	45 (11,9)	CW
300 (12)	36 (79)	53 (14,0)	AF
300 (12)	36 (79)	53 (14,0)	CW
350 (14)	40 (88)	65 (17,2)	AF
350 (14)	40 (88)	65 (17,2)	CW
400 (16)	44 (97)	77 (20,3)	AF
400 (16)	44 (97)	77 (20,3)	CW

OPTIONAL

4	4	5
DC teeth	DTE teeth	CW reversible version

* weight of the tank excluding attachment

* weight of the tank excluding attachment

BN66 MACHINE WEIGHT 4,0 - 6,0 t (8818 - 13228 lb)

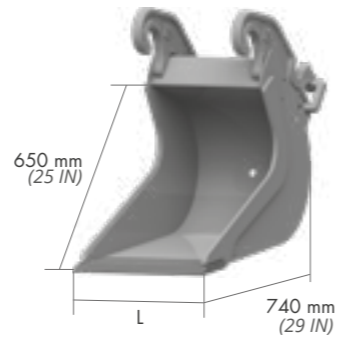
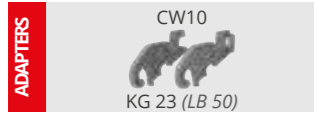

L mm (in)	WEIGHT Kg* (lb*)	CAP. SAE l (gal)	
220 (9)	39 (86)	42 (11,1)	AF
220 (9)	39 (86)	42 (11,1)	CW
250 (10)	42 (93)	50 (13,2)	AF
250 (10)	42 (93)	50 (13,2)	CW
300 (12)	48 (106)	77 (20,3)	AF
300 (12)	48 (106)	77 (20,3)	CW
350 (14)	51 (112)	83 (21,9)	AF
350 (14)	51 (112)	83 (21,9)	CW
400 (16)	56 (123)	92 (24,3)	AF
400 (16)	56 (123)	92 (24,3)	CW

OPTIONAL

4	4	5
DC teeth	DTE teeth	CW reversible version

BN75 MACHINE WEIGHT 6,0 - 7,5 t (13228 - 16535 lb)

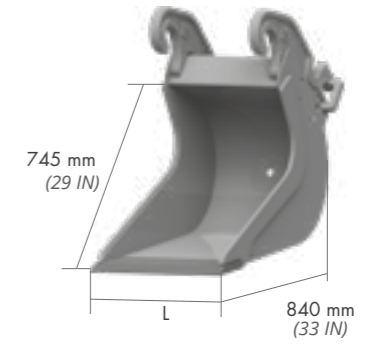
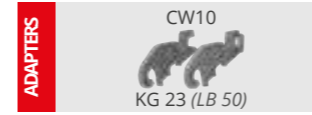

L mm (in)	WEIGHT Kg* (lb*)	CAP. SAE l (gal)	
250 (10)	67 (148)	59 (15,6)	AF
250 (10)	67 (148)	59 (15,6)	CW
300 (12)	71 (157)	74 (19,5)	AF
300 (12)	71 (157)	74 (19,5)	CW
350 (14)	73 (161)	91 (24,0)	AF
350 (14)	73 (161)	91 (24,0)	CW
400 (16)	74 (163)	106 (28,0)	AF
400 (16)	74 (163)	106 (28,0)	CW

OPTIONAL

4	4	5
DC teeth	DTE teeth	CW reversible version

BN90 MACHINE WEIGHT 7,5 - 12,0 t (16535 - 26455 lb)

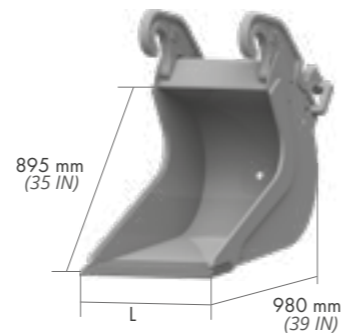
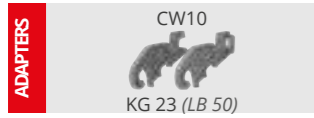

L mm (in)	WEIGHT Kg* (lb*)	CAP. SAE l (gal)	
300 (12)	90 (198)	78 (20,6)	AF
300 (12)	90 (198)	78 (20,6)	CW
350 (14)	96 (212)	100 (26,4)	AF
350 (14)	96 (212)	100 (26,4)	CW
400 (16)	100 (220)	123 (32,5)	AF
400 (16)	100 (220)	123 (32,5)	CW
450 (18)	106 (234)	146 (38,6)	AF
450 (18)	106 (234)	146 (38,6)	CW
500 (20)	115 (254)	171 (45,2)	AF
500 (20)	115 (254)	171 (45,2)	CW

OPTIONAL

4	4	5
DC teeth	DTE teeth	CW reversible version

* weight of the tank excluding attachment

* weight of the tank excluding attachment

** no AR for 10-12 tons